

- SWE MONTERINGSANVISNING SKANDIC  
 GBR MOUNTING INSTRUCTIONS SKANDIC  
 DEN MONTERINGSANVISNING SKANDIC  
 NOR MONTERINGSANVISNING SKANDIC  
 FIN SKANDIC YKSIOTEHANOJEN ASENNUSOOHJE  
 EST SKANDIC PAIGALDUSJUHEND  
 LAT UZSTĀDĪŠANAS INSTRUKCIJA SKANDIC  
 LTU SKANDIC MONTAVIMO INSTRUKCIJA  
 UKR ІНСТРУКЦІЯ З МОНТАЖУ SKANDIC  
 CZE MONTÁŽNÍ NÁVOD SKANDIC BATERIE  
 SVK MONTÁŽNY NÁVOD SKANDIC BATÉRIE  
 ROU INSTRUCȚIUNI DE MONTARE SKANDIC

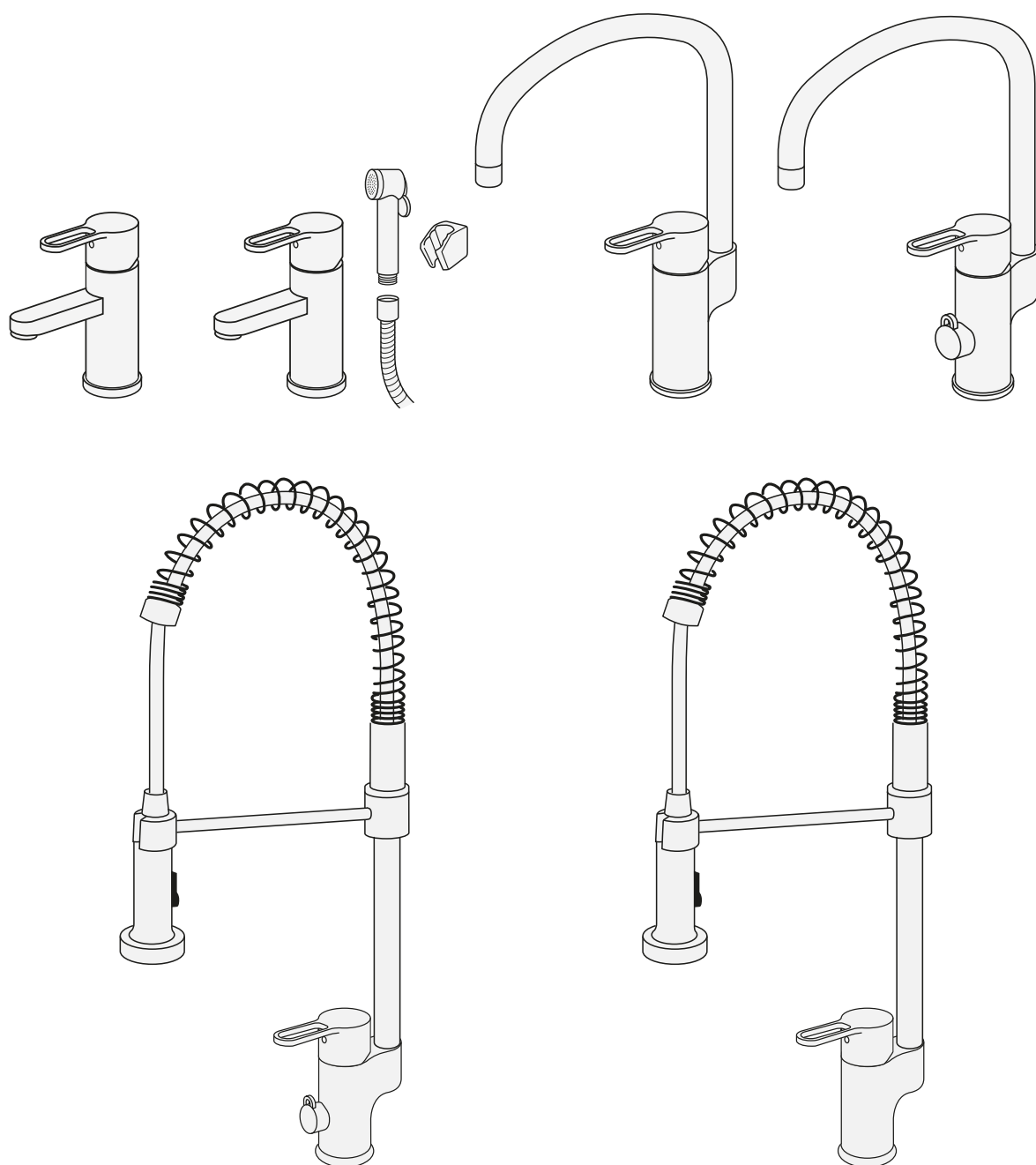

	Garanti. Takuu. Guarantee. Garantii. Garantija. Garantija. Гарантія.		3/14	
	Skandic		4/14	
	Skandic		5/14	
			6/14	
			6/14	
			7/14	
		Justera komfortflöde Adjustment water saving Justere vandmængde Justere komfortmengde Säästövirtaaman säätö Настройка функции водосбережения	Veehulga reguleerimine Ūdens taupišanas regulēšana Vandens taupymo reguliuotojas Налаштування збереження води Nastavení úspory vody Nastavenie úspory vody	8/14
		Begränsa temperaturen Limit temperature Begrænse temperaturen Begrænse temperaturen Kuuman veden rajoittaminen Настройка ограничителя температуры	Temperatuuri piiramine Temperatūras ierobežošana Ribota temperatūra Лімітування температури Hraniční teplota Hraničná teplota	8/14
		Skötsel Maintenance Beskyttelse Vedlikehold Hoito-ohje Уход	Hooldus Kopšanas informācija Montavimas Догляд Річчє о батєрії Starostlivost o batériu	9/14
		Rengöring Clean Rengøring Rengjøring Puhdistus очистка	Puhastamine Tīrīšana Švarus Очищення Čistý	9-10/14
			11/14	
	Reservdelar. Reservedeler. Reservedele. Varaosat. Spare parts. Varuosad. Atsarginės dalys. Rezerves daļas. Запасные части.		12-13/14	

## SE GARANTI

Produkten har garanti enligt respektive lands gällande branschvillkor.

### Direktiv vid reklamation

Våra produkter är tillverkade enligt väldigt stränga kvalitetskrav. Om en produkt trots det är felaktig, ber vi er i första hand att kontakta din återförsäljare. Ärendet underlättas genom att uppvisa kvitto och uppge produktnummer och inköpsdatum.

## DK GARANTI

Produktet har garanti i forhold til gældende dansk lovgivning.

### Vejledning ved reklamation

Vores produkter er fremstillet i overensstemmelse med markedets strengeste krav til kvalitet. Skulle produktet mod forventning være behæftet med fejl henviser vi til den forhandler, hvor produktet er købt. Kvittering skal kunne fremvises, hvis forhandleren forlanger det, ligesom oplysninger om produktnummer og købsdato skal kunne dokumenteres.

## NO GARANTI

Produktene har garanti i henhold til respektive lands gjeldende bransjevilkår.

### Instrukser ved reklamasjon

Våre produkter er produsert i henhold til veldig strenge kvalitetskrav. Om et produkt til tross for dette skulle være feilaktig, ber vi deg vennligst ta kontakt med forhandleren. Vi ber deg medbringe kvittering og oppgi innkjøpsdato samt produktnummer.

## FI TAKUU

Noudatamme alamme yleisiä toimitusehtoja.

### Reklamaatio

Tuotteemme ovat valmistettu Villeroy & Boch in ja Gustavsbergin laatuvaatimuksien mukaisesti. Mikäli tuote kuitenkin on virheellinen pyydämme teitä kääntymään ensisijaisesti tuotteen myyjän puoleen. Käsitelyyn helpottamiseksi säilyttäkää tosite tuotteen ostosta.

## GB GUARANTEE

The product has a guarantee accordingly to industry rules in every country.

### Instructions for complaints

Our products are made according to very strict quality demands. If the product is faulty in spite of that we ask you kindly to take it to your retailer. We also ask you to bring the receipt and be prepared to inform about the product number and purchasing date.

## EE GARANTII

Antud tootel on garantii vastavalt tehase poolt kehtestatud tingimustele.

### Juhised reklamatsioonide käsitlemiseks

Meie tooted on valmistatud silmas pidades väga täpseid kvaliteedistandardeid. Juhul kui olete saanud praaktoote, palume Teil toimetada see kas meie edasimüüja juurde või võtta ühendust esindusega. Samuti palume alles hoida ostutšekk ning vajadusel anda informatsiooni tootenumbri ja ostu sooritamise aja kohta.

## LV GARANTIJA

Izstrādājumam ir garantija saskaņā ar ražotāja standartiem.

### Instrukcija kvalitātes problēmu gadījumā

Mūsu produkcija tiek ražota pēc ļoti striktiem kvalitātes kritērijiem. Taču – gadījumā, ja produktam tiek konstatēta kvalitātes problēma – lūdzam, sazinieties ar pārdevēju. Lūdzam, esiet gatavi arī uzrādīt pirkuma čeku ar pirkuma datumu.

## LT GARANTIJA

Gaminiams garantija suteikiama atsižvelgiant į konkrečios šalies kokybės reikalavimus.

### Reklamacijos

Mūsų produkcija pagaminta vadovaujantis griežtais kokybės reikalavimais. Jei gaminys nekokybiškas – prašome jį grąžinti pardavėjui, pateikiant pirkimo čekį, gaminio numerį bei nurodant pirkimo datą.

## ГАРАНТІЯ

Ця продукція підтримується гарантією у відповідності з правилами та законами, що діють у країні збуту.

### Рекламації

Наша продукція відповідає сучасним стандартам та вимогам щодо якості. У випадку виникнення несправності, Ви можете звернутися в торгову організацію, де був придбаний цей виріб. Для оформлення рекламації необхідно додати супровідні документи щодо виробу та чек, що підтверджує найменування та дату покупки

## RU ГАРАНТИЯ

Гарантийные условия устанавливаются в соответствии с законами и правилами, которые действуют в стране сбыта.

### Рассмотрение рекламаций

Наша продукция соответствует современным стандартам и требованиям к качеству. В случае возникновения неисправности Вы можете обратиться в торговую организацию, где было приобретено данное изделие. При заявлении рекламации необходимо предъявить сопроводительные документы к данной продукции и чек, подтверждающий дату покупки.

## GARANTII

Antud tootele kehtivad garantiitingimused tulenevad kohalikest õigusaktidest.

### Juhised reklamatsioonide käsitlemiseks

Meie tooted on valmistatud silmas pidades väga täpseid kvaliteedistandardeid. Juhul kui olete saanud praaktoote, palume Teil toimetada see kas meie edasimüüja juurde või võtta ühendust esindusega. Samuti palume alles hoida ostutšekk ning vajadusel anda informatsiooni tootenumbri ja ostu sooritamise aja kohta.

## GARANTIJA

Produktam ir garantija atbilstoši nozares noteikumiem konkrētajā valstī.

### nstrukcijas sūdzību pieteikšanai

Mūsu produkti ir izgatavoti saskaņā ar ļoti stingriem kvalitātes prasībām. Tomēr, ja produkts ir bojāts, mēs lūdzam griezties produkta iegādes vietā. Mēs lūdzam arī sagatavot uzrādīšanai pirkuma čeku un informāciju par pirkuma datumu.

## GARANTIJA

Gaminiams garantija suteikiama atsižvelgiant į konkrečios šalies kokybes reikalavimus.

### Pretenzijos

Mūsų produkcija pagaminta vadovaujantis griežtais kokybes reikalavimais. Jei gaminys nekokybiškas – prašome jį grąžinti pardavėjui, pateikiant pirkimo čekį, bei nurodyti pirkimo datą



# SKANDIC

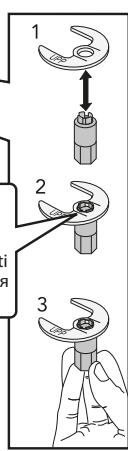
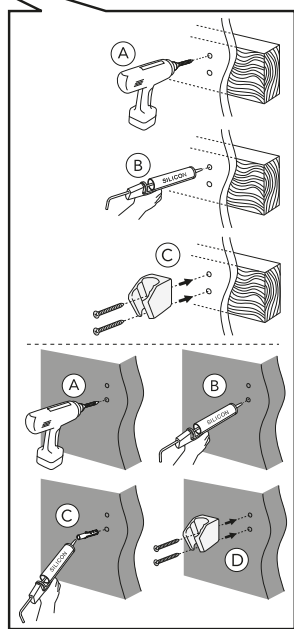
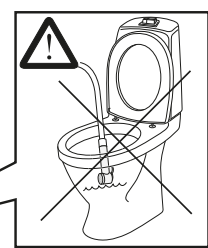
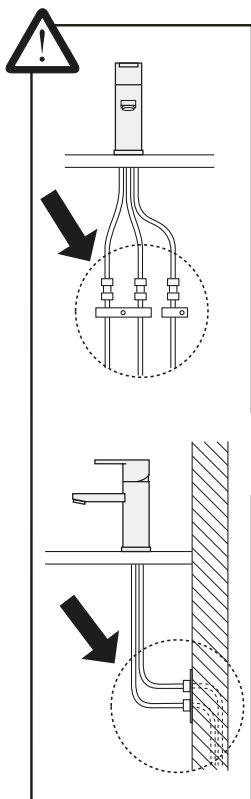
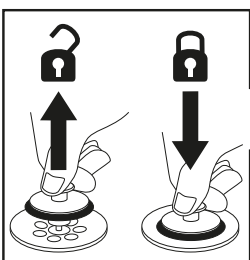
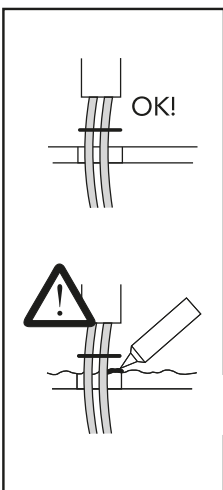
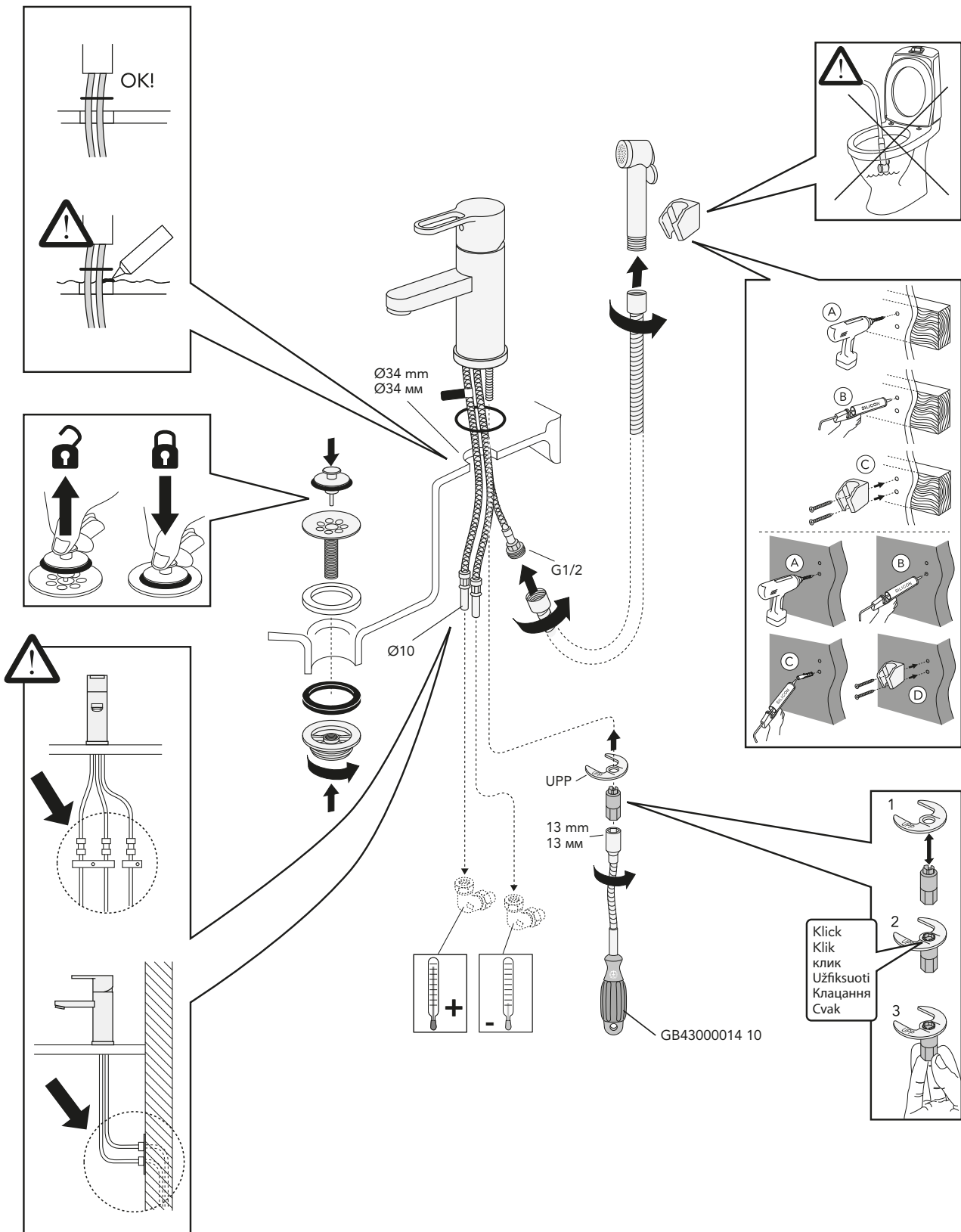

Klik  
 Клік  
 клик  
 Užņksuoti  
 Клацання  
 Свак



# SKANDIC

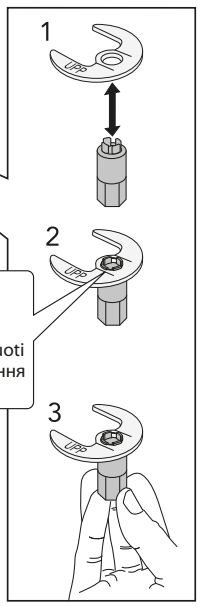
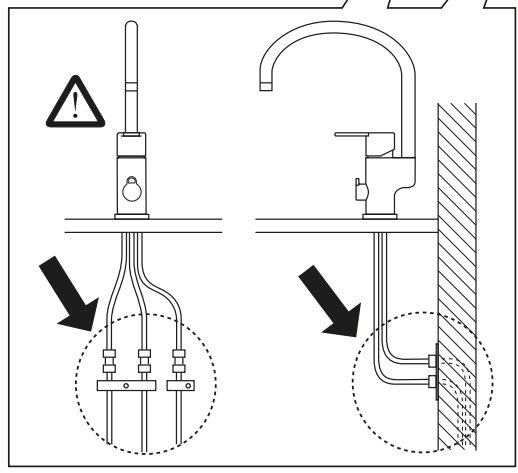
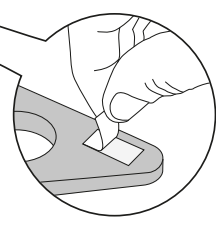
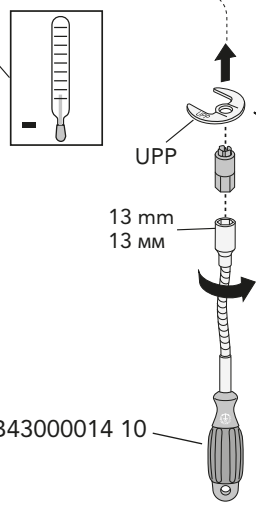
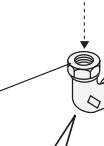
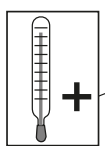
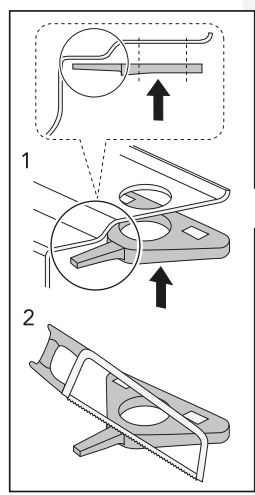
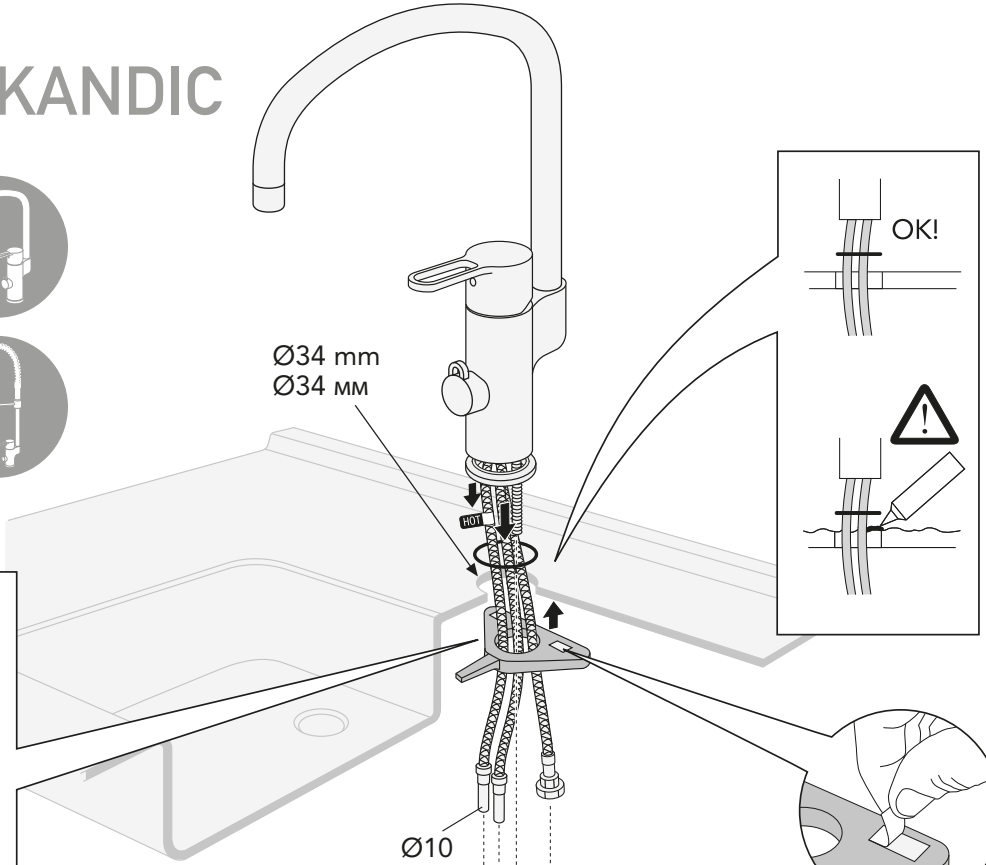

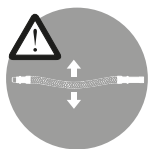

# SOFTPEX

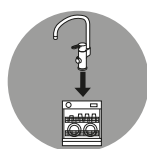
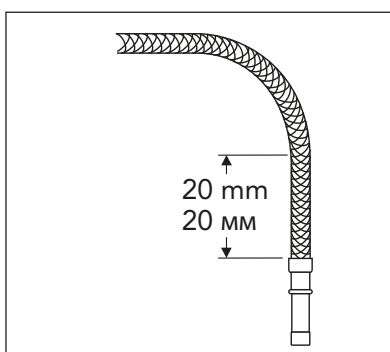
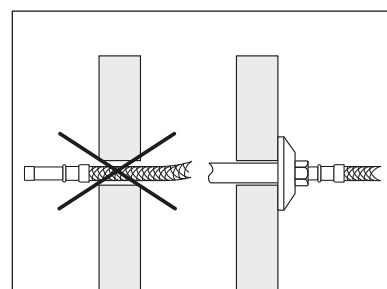
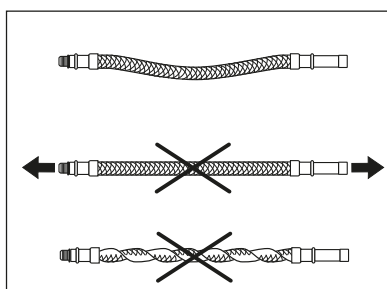
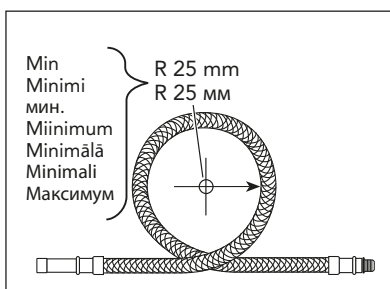

# SKANDIC

10°C → 60°C

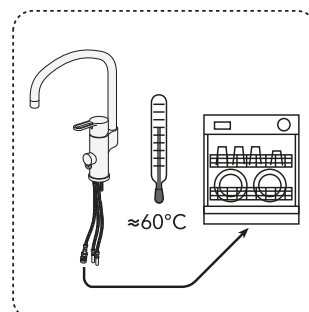
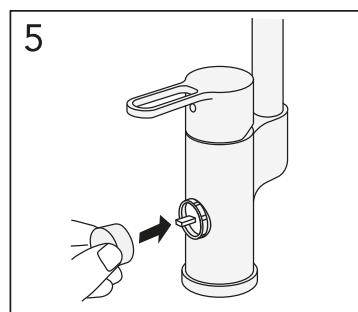
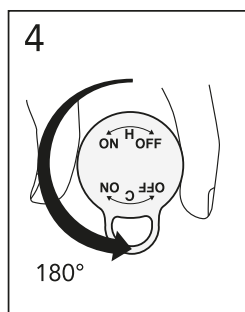
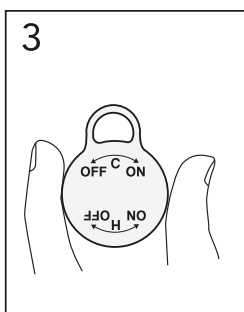
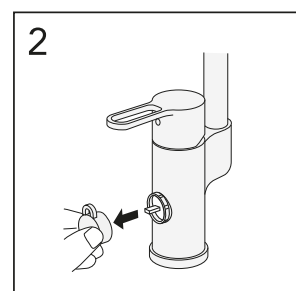
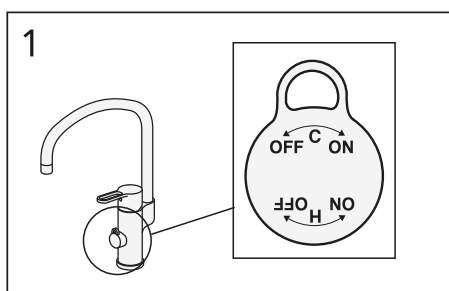
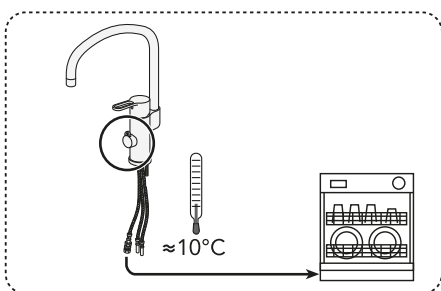



# SKANDIC

Pip  
Spout  
Tud  
Tut  
Juoksuputki  
излив  
Jooksutoru  
Snipis  
Snaras  
Вилив  
Ustí  
Ústie

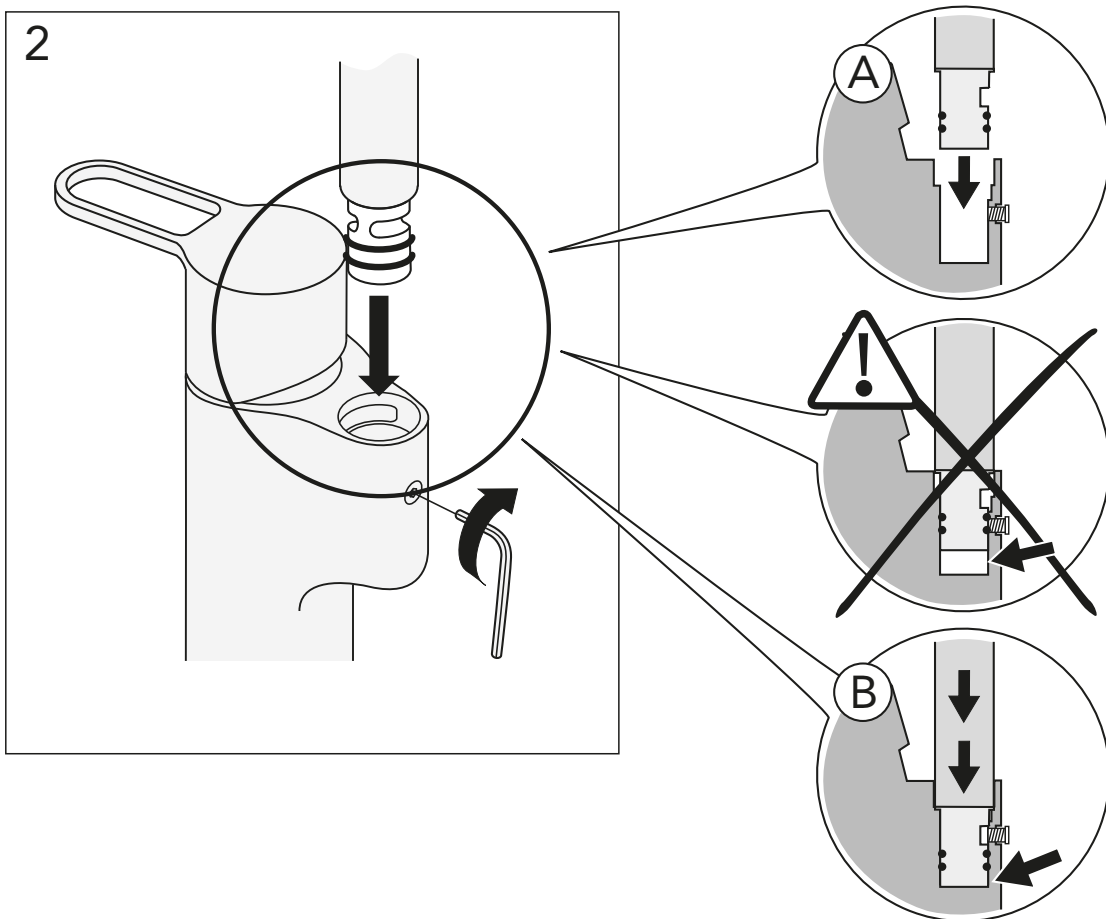
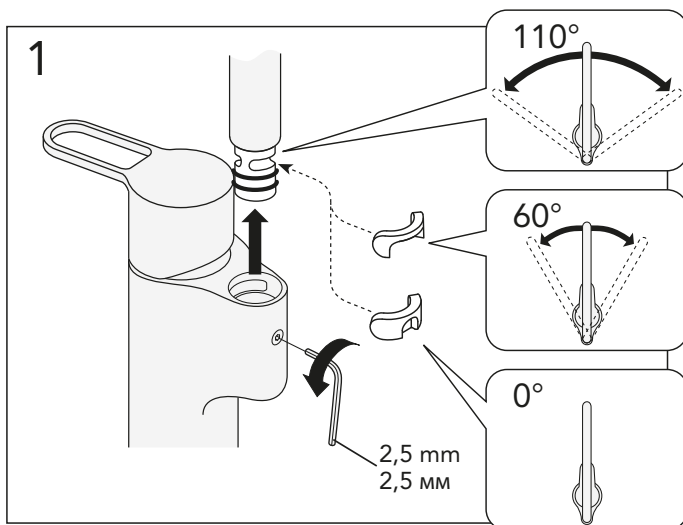
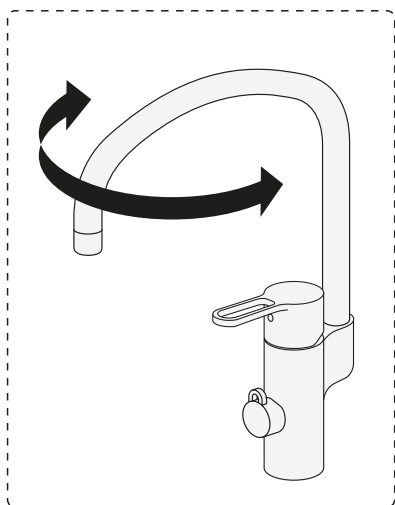



Justera komfortflöde  
 Adjustment water saving  
 Justere vandmængde  
 Justere komfortmengde  
 Säastövirtaaman säätö  
 Настройка функции водосбережения  
 Veehulga reguleerimine  
 Ūdens taupišanas regulēšana  
 Vandens taupymo reguliuotojas  
 Наставлення збереження води  
 Nastavení úspory vody  
 Nastavenie úspory vody

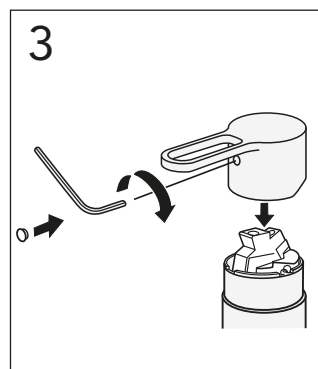
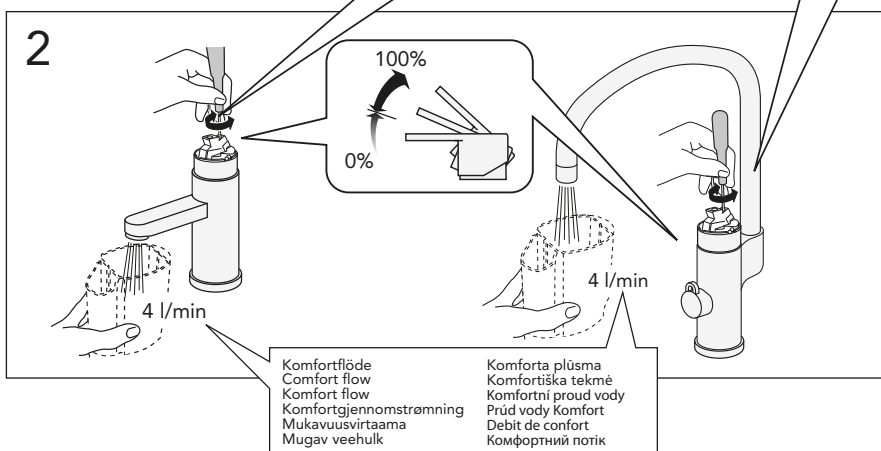
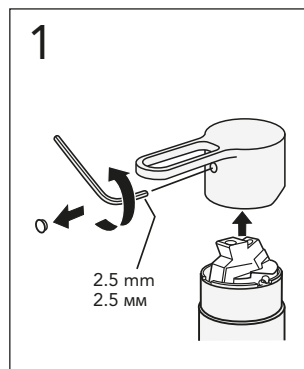
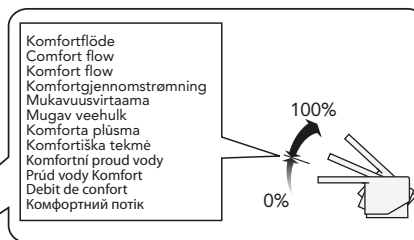

Begränsa temperaturen  
 Limit temperature  
 Begrænse temperaturen  
 Begrense temperaturen  
 Kuuman veden rajoittaminen  
 Настройка ограничителя температуры  
 Temperatuuri piiramine  
 Temperatūras ierobežošana  
 Ribota temperatūra  
 Лімітування температури  
 Hraníční teplota  
 Hraníčná teplota

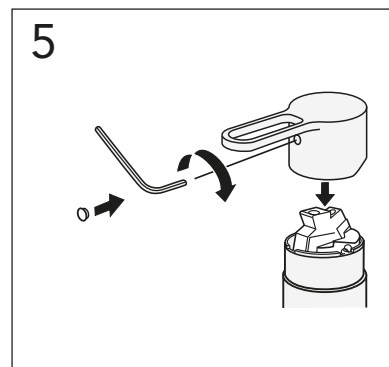
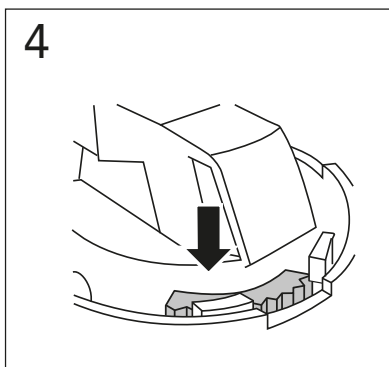
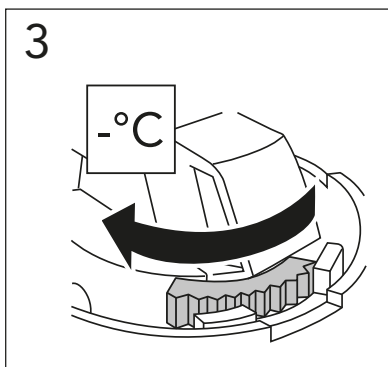
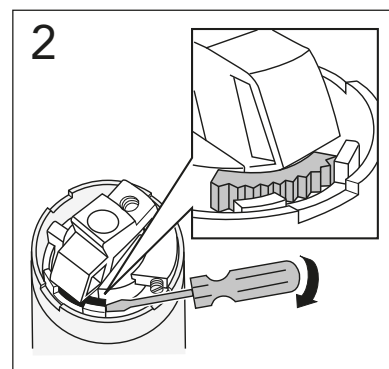
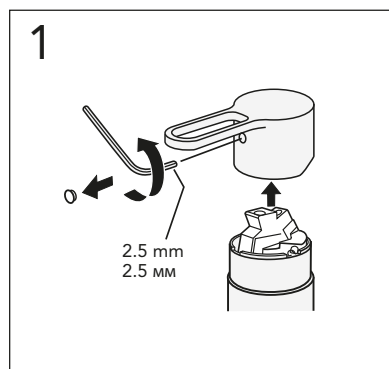





## SKANDIC

Skötsel  
Maintenance  
Beskyttelse  
Vedlikehold  
Hoito-ohje  
Уход  
Hooldus  
Kopšanas informācija  
Montavimas  
Догляд  
Péče o baterii  
Starostlivosť o batériu

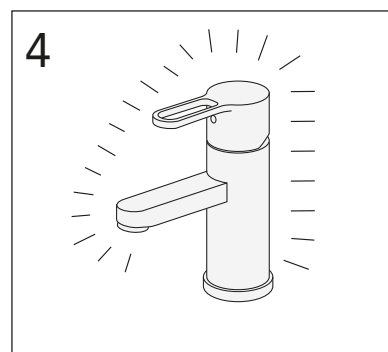
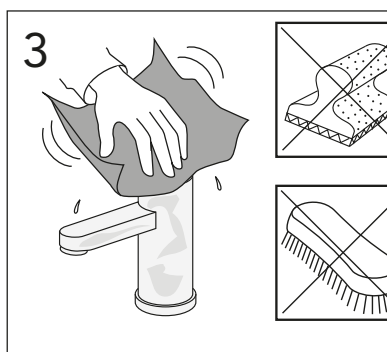
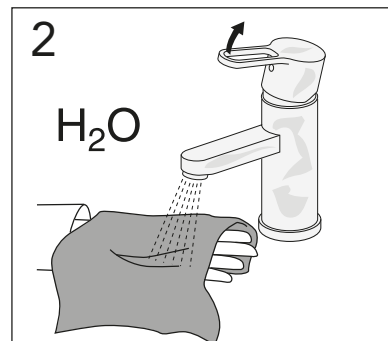
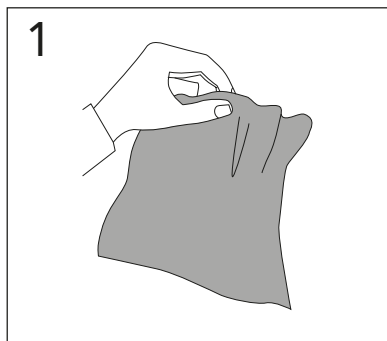

## SKANDIC

Rengöring  
Clean  
Rengøring  
Rengjøring  
Puhdistus  
очистка  
Puhastamine  
Tīrīšana  
Švarus  
Очищення  
Čistý

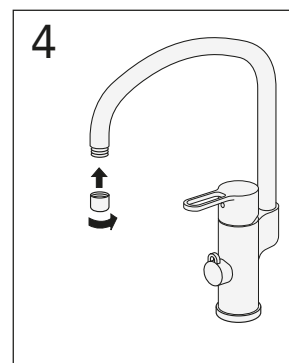
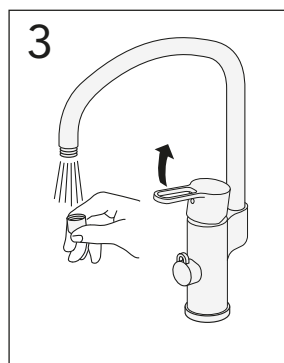
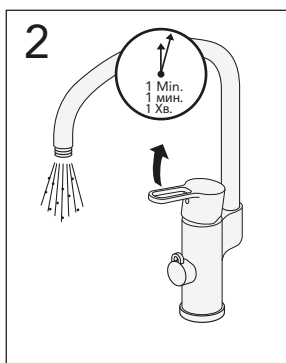
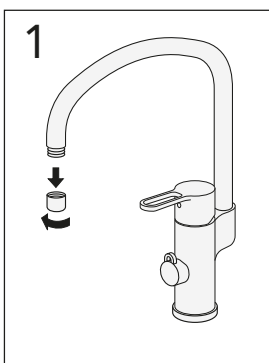
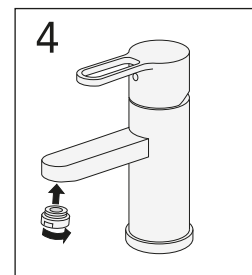
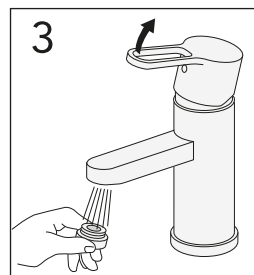
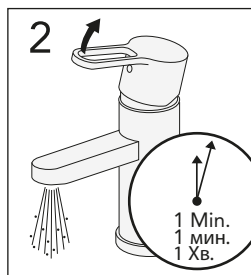
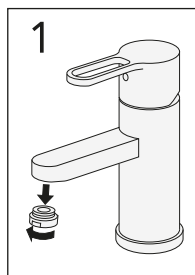



# SKANDIC

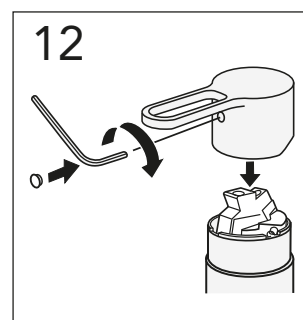
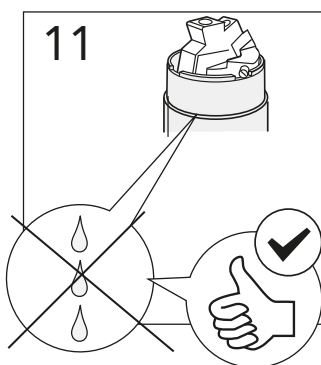
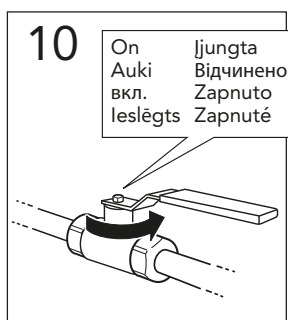
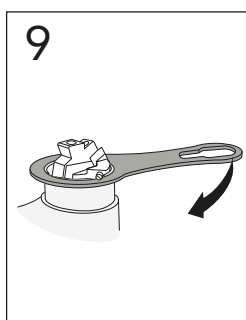
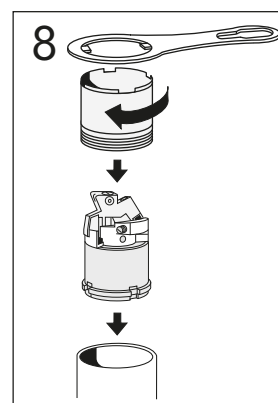
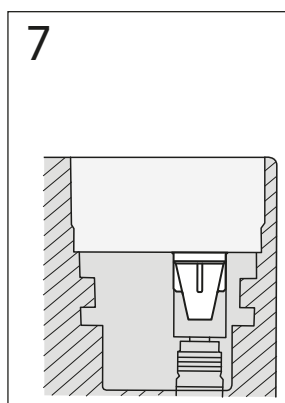
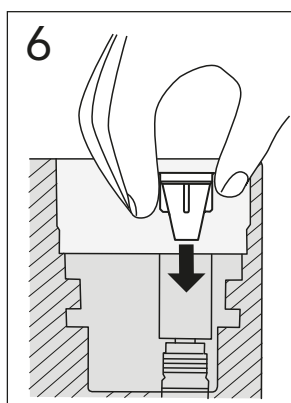
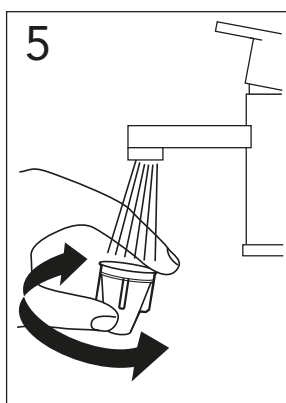
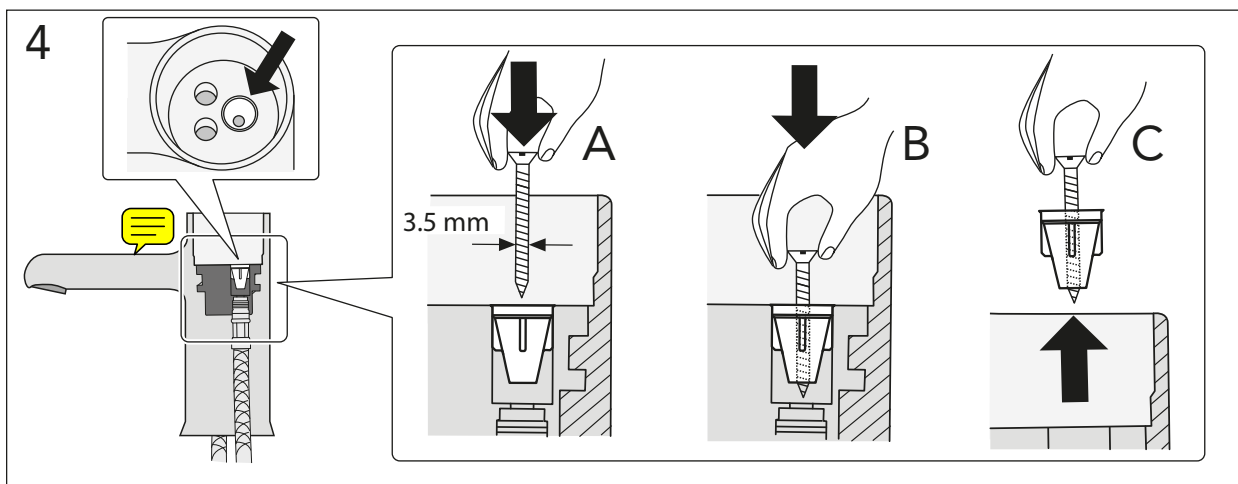
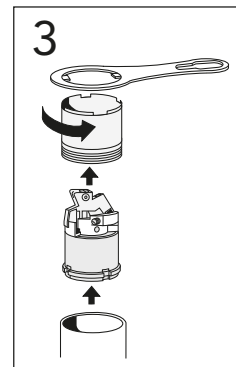
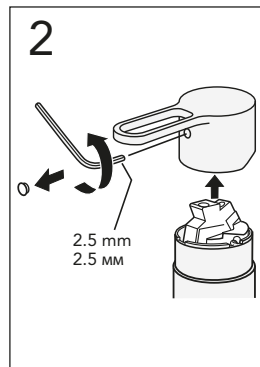
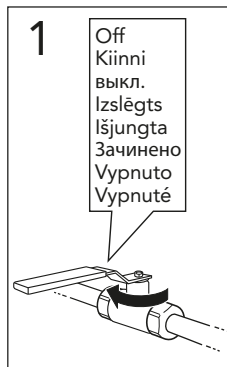
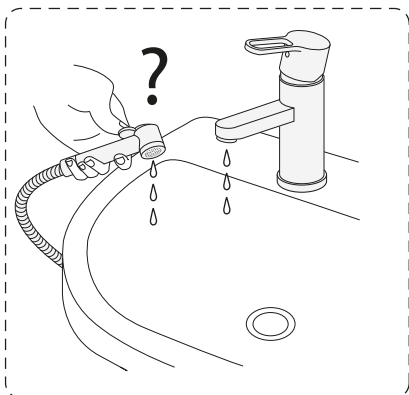

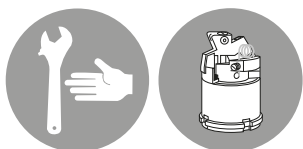

# SKANDIC

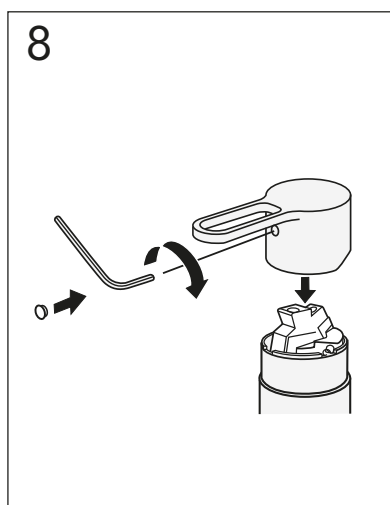
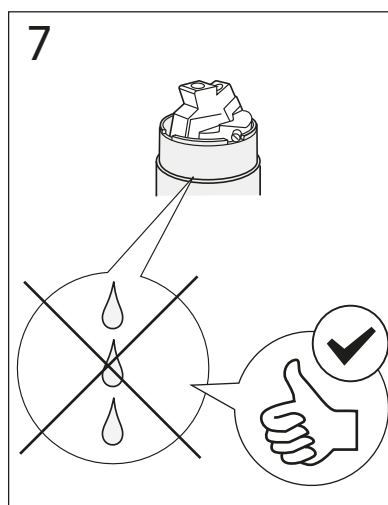
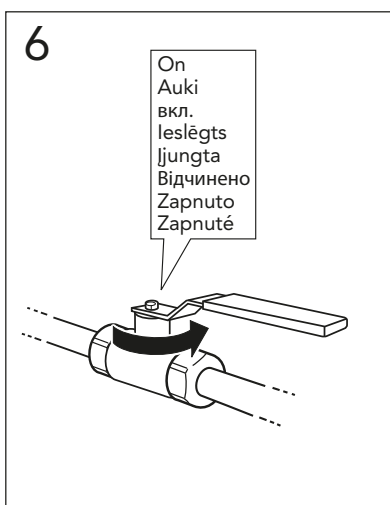
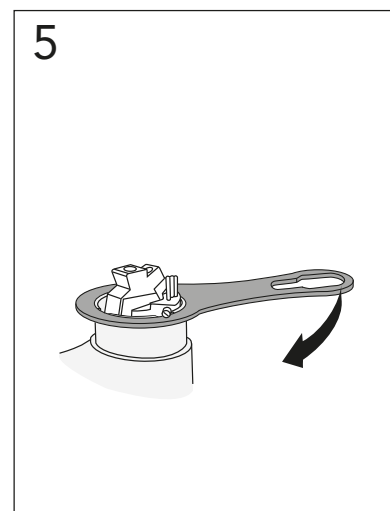
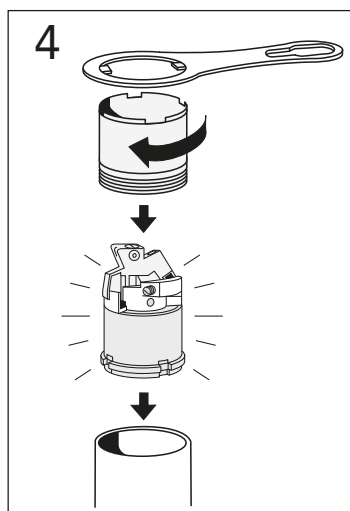
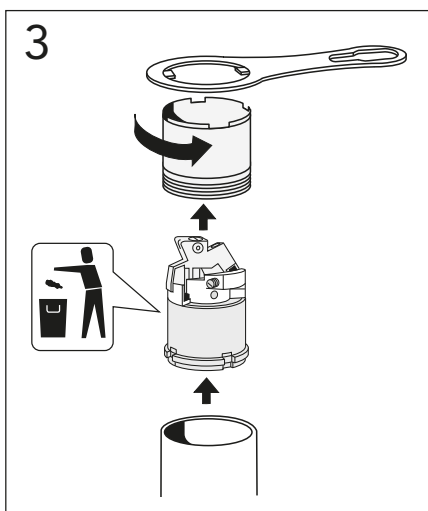
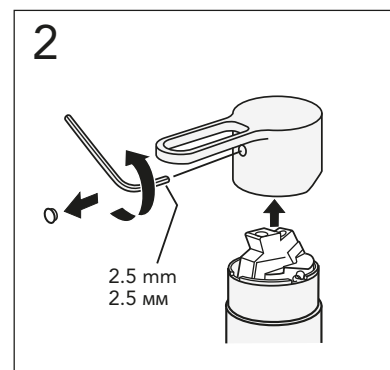
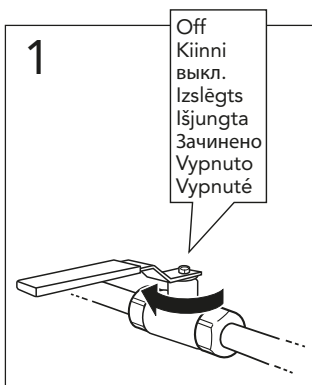
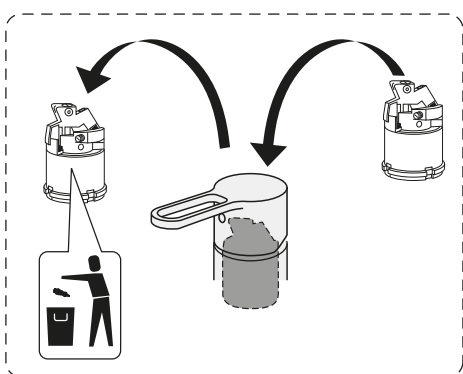
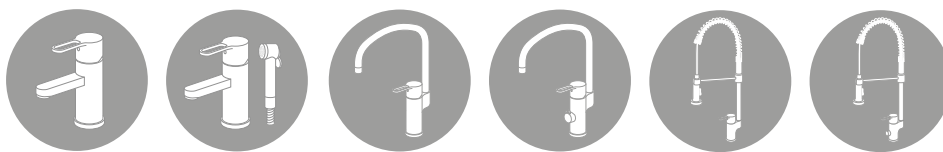

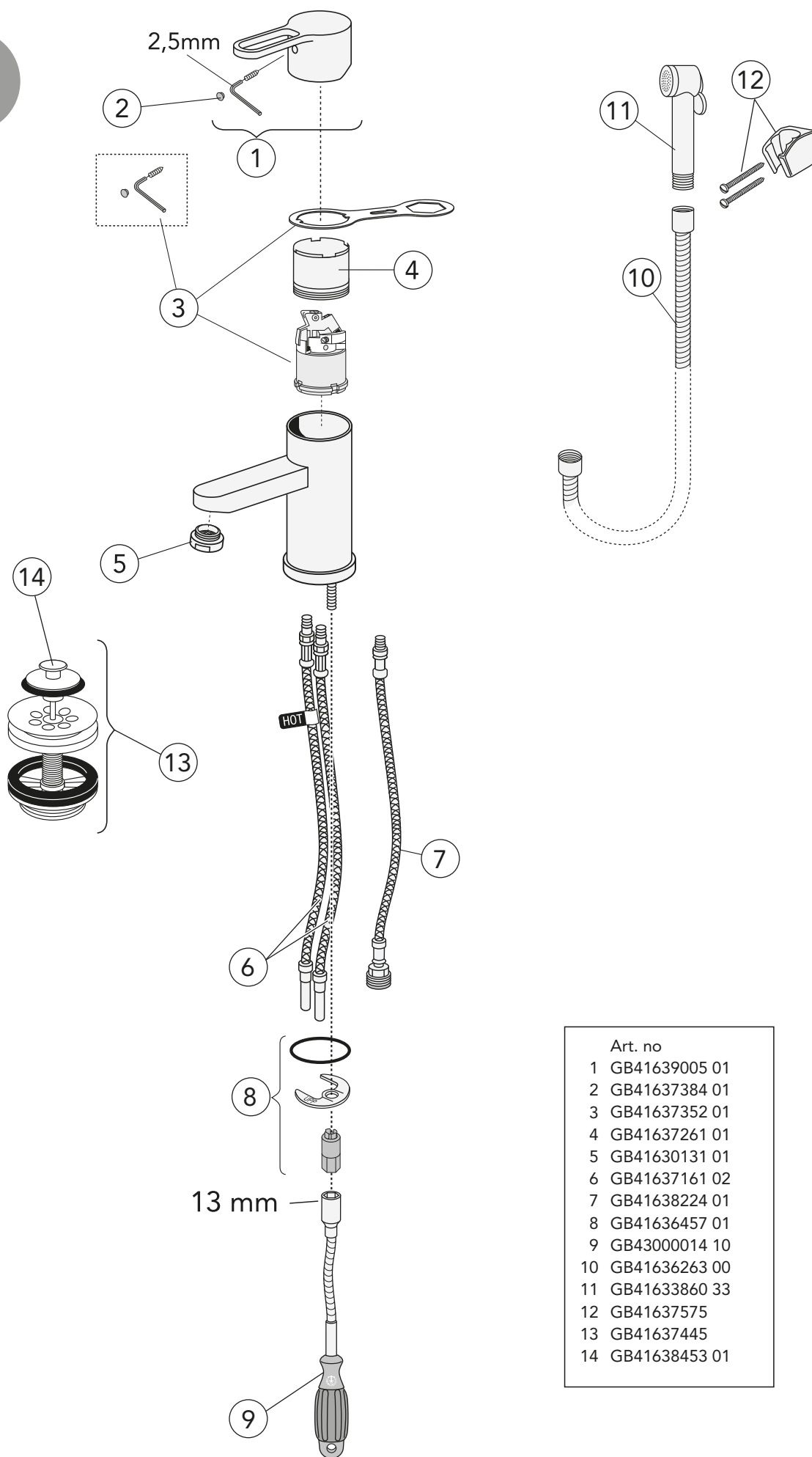

Art. no
1 GB41639005 01
2 GB41637384 01
3 GB41637352 01
4 GB41637261 01
5 GB41630131 01
6 GB41637161 02
7 GB41638224 01
8 GB41636457 01
9 GB43000014 10
10 GB41636263 00
11 GB41633860 33
12 GB41637575
13 GB41637445
14 GB41638453 01

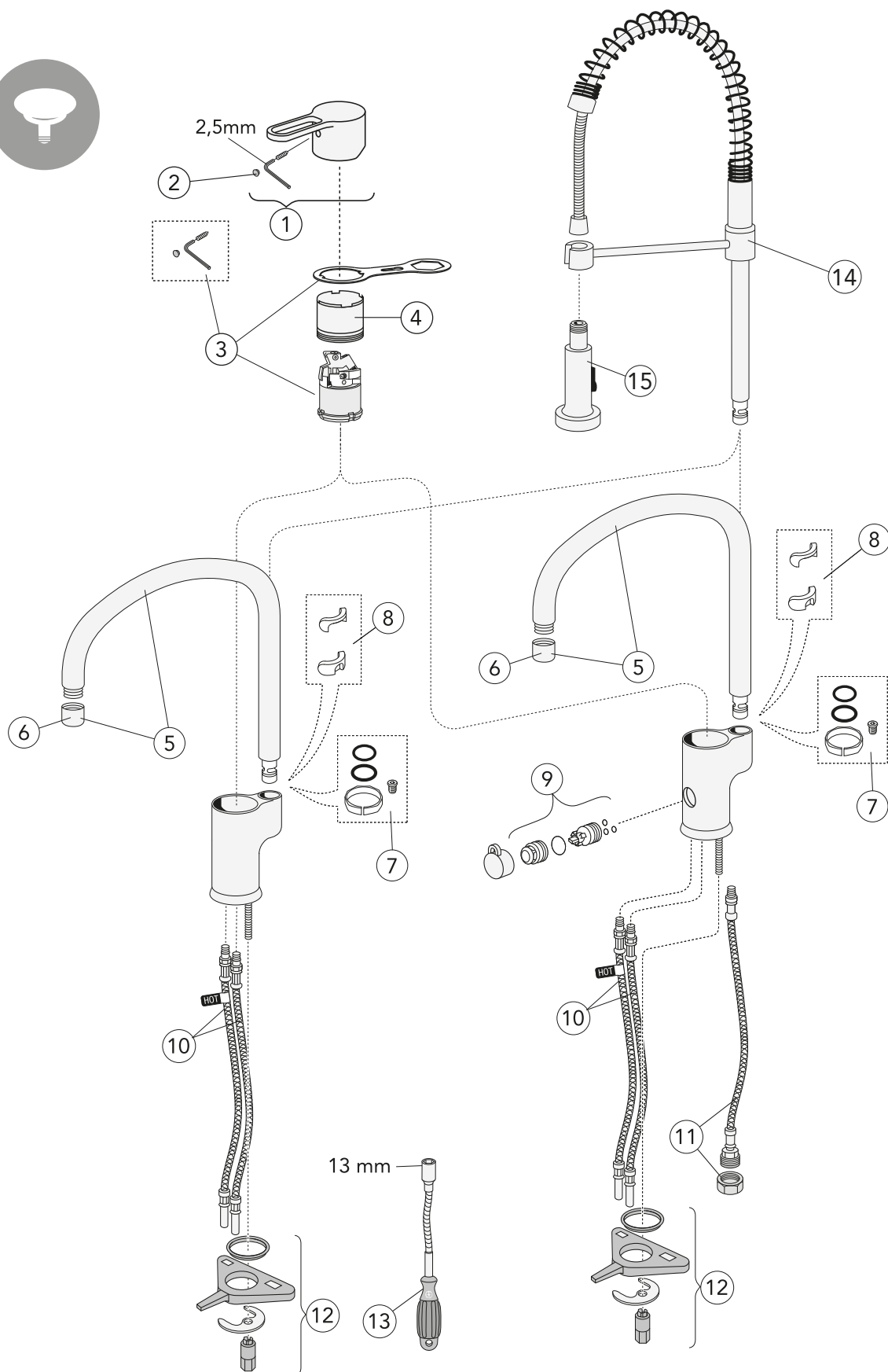











Art. no	Art. no	Art. no
1 GB41639005 01	6 GB41630129 01	11 GB41638220 01
2 GB41637384 01	7 GB41637010 01	12 GB41634157 01
3 GB41637352 01	8 GB41638450	13 GB43000014 10
4 GB41637261 01	9 GB41635762 3301	14 GB41638753 01
5 GB41638474 01	10 GB41637161 02	15 GB41638754 01



www.gustavsberg.com



-  Sweden / Sverige
-  English
-  Denmark / Danmark
-  Finland / Suomi
-  Norway / Norge
-  Estonia / Eesti
-  Russia / Россия
-  Latvia / Latvija
-  Lithuania / Lietuva
-  Ukraine / Україна

DRIFT & SKÖTSEL  
 DRIFT OG VEDLIGEHOLDELSE  
 DRIFT OG VEDLIKEHOLD  
 ASENNUS-, KÄYTTÖ- JA HOITO-OHJEET  
 ASSEMBLY AND MAINTENANCE  
 PAIGALDAMINE & HOOLDAMINE  
 MONTĀŽA UN KOPŠANA  
 MONTAVIMAS IR PRIEŽIŪRA  
 Сборка и техническая поддержка  
 MONTÁŽ A ÚDRŽBA

LANGUAGE



SUPPORT



A MEMBER OF THE  
 VILLEROY & BOCH GROUP

Sweden  
 Villeroy & Boch Gustavsberg AB  
 Box 400  
 134 29 Gustavsberg  
 Phone +46 8 570 391 00  
 info@gustavsberg.com

Norway  
 Villeroy & Boch Norge AS  
 Luhrtoppen 2  
 Postboks 13  
 1471 Lorenskog  
 Tlf. + 47 67 97 82 50  
 info.norway@gustavsberg.no

Estonia  
 Villeroy & Boch Gustavsberg Oy Eesti Filiaal  
 F. R. Faehmanni 6  
 10125 Tallinn  
 Telefon + 372 646 0312  
 E-mail: info@gustavsberg.ee

Lithuania  
 Villeroy & Boch Gustavsberg Oy Filialas  
 Maironio 25-23,  
 Vilnius LT-01125  
 Tel.: +370 5 2460811  
 El.paštas: infolt@gustavsberg.com

Russia  
 ООО "Виллерой и Бох"  
 127287 Москва  
 ул. 2я Хуторская, д.38А19  
 Тел.: + 7 495 609 6560  
 info.russia@gustavsberg.com

Denmark  
 Villeroy & Boch Danmark A/S  
 Hvidsværmervej 165 G  
 2610 Redovre  
 Tlf + 45 36 70 80 55  
 info@gustavsberg.dk

Suomi/Finland  
 Villeroy & Boch Gustavsberg Oy  
 Laippatie 14 b  
 00880 Helsinki  
 Puh +358 9 329 18 811  
 myynti@gustavsberg.com

Latvia  
 Villeroy & Boch Gustavsberg Oy parstavnieciba Latvija  
 Krasta iela 68 A  
 LV - 1019 Riga. Latvija  
 Tālrunis: +371 6724 5511  
 e-pasts: info.latvia@gustavsberg.com

Україна  
 Представництво Villeroy & Boch Gustavsberg в Україні  
 вул. Богдана Хмельницького 17/52а, оф. 401а,  
 м. Київ, 01030  
 тел: +38044 493 98 68  
 info@gustavsberg.kiev.ua

Czech Republic / Slovakia  
 Villeroy & Boch Czech s.r.o.  
 Türkova 2319/5b  
 149 00 Praha 4 - Chodov  
 Czech Republic  
 Tel: +420 271 001 647  
 info-cz@villeroy-boch.com