

SWE MONTERINGSANVISNING COLORIC
GBR MOUNTING INSTRUCTIONS COLORIC
DEN MONTERINGSANVISNING COLORIC
NOR MONTERINGSANVISNING COLORIC
FIN COLORIC YKSIOTEHANOJEN ASENNUSOHJE
EST COLORIC PAIGALDUSJUHEND
LAT UZSTĀDĪŠANAS INSTRUKCIJA COLORIC
LTU COLORIC MONTAVIMO INSTRUKCIJA
UKR ІНСТРУКЦІЯ З МОНТАЖУ COLORIC
CZE MONTÁŽNÍ NÁVOD COLORIC BATERIE
SVK MONTÁŽNY NÁVOD COLORIC BATÉRIE
ROU INSTRUCȚIUNI DE MONTARE COLORIC

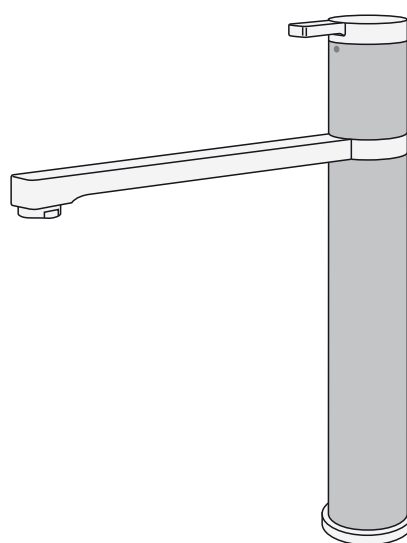
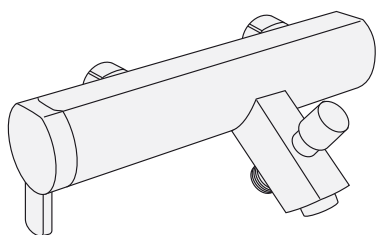
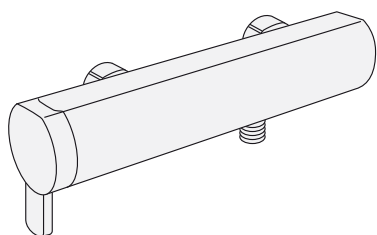
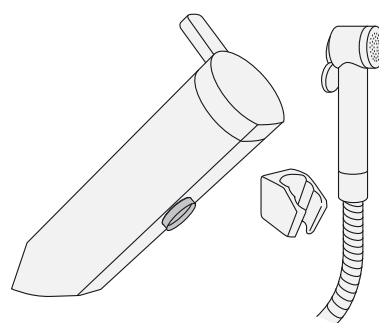
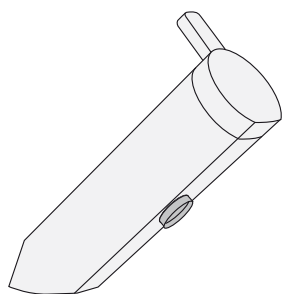

	Garanti. Takuu. Guarantee. Garantii. Garantija. Garantija. Гарантия.		3/13
	Skandic		4/13
	Skandic		5/13
			6/13
			6/13
			7/13
	Justera komfortflöde Adjustment water saving Justere vandmængde Justere komfortmengde Säästövirtaaman säätö Настройка функции водосбережения	Veehulga reguleerimine Ūdens taupišanas regulēšana Vandens taupymo reguliuotojas Налаштування збереження води Nastavení úspory vody Nastavenie úspory vody	8/13
	Skötsel Maintenance Beskyttelse Vedlikehold Hoito-ohje Уход	Hooldus Kopšanas informācija Montavimas Догляд Рѣче о батерии Starostlivost o batériu	9/13
	Rengöring Clean Rengøring Rengjøring Puhdistus очистка	Puhastamine Tīrīšana Švarus Очищення Čistý	9-10/13
			11/13
	Reservdelar. Reservedeler. Reservedele. Varaosat. Spare parts. Varuosad. Atsarginės dalys. Rezerves daļas. Запасные части.		12/13

SE GARANTI

Produkten har garanti enligt respektive lands gällande branschvillkor.

Direktiv vid reklamation

Våra produkter är tillverkade enligt väldigt stränga kvalitetskrav. Om en produkt trots det är felaktig, ber vi er i första hand att kontakta din återförsäljare. Ärendet underlättas genom att uppvisa kvitto och uppge produktnummer och inköpsdatum.

DK GARANTI

Produktet har garanti i forhold til gældende dansk lovgivning.

Vejledning ved reklamation

Vores produkter er fremstillet i overensstemmelse med markedets strengeste krav til kvalitet. Skulle produktet mod forventning være behæftet med fejl henviser vi til den forhandler, hvor produktet er købt. Kvittering skal kunne fremvises, hvis forhandleren forlanger det, ligesom oplysninger om produktnummer og købsdato skal kunne dokumenteres.

NO GARANTI

Produktene har garanti i henhold til respektive lands gjeldende bransjevilkår.

Instrukser ved reklamasjon

Våre produkter er produsert i henhold til veldig strenge kvalitetskrav. Om et produkt til tross for dette skulle være feilaktig, ber vi deg vennligst ta kontakt med forhandleren. Vi ber deg medbringe kvittering og oppgi innkjøpsdato samt produktnummer.

FI TAKUU

Noudatamme alamme yleisiä toimitusehtoja.

Reklamaatio

Tuotteemme ovat valmistettu Villeroy & Boch in ja Gustavsbergin laatuvaatimuksien mukaisesti. Mikäli tuote kuitenkin on virheellinen pyydämme teitä kääntymään ensisijaisesti tuotteen myyjän puoleen. Käsitelyyn helpottamiseksi säilyttäkää tosite tuotteen ostosta.

GB GUARANTEE

The product has a guarantee accordingly to industry rules in every country.

Instructions for complaints

Our products are made according to very strict quality demands. If the product is faulty in spite of that we ask you kindly to take it to your retailer. We also ask you to bring the receipt and be prepared to inform about the product number and purchasing date.

EE GARANTII

Antud tootel on garantii vastavalt tehase poolt kehtestatud tingimustele.

Juhised reklamatsioonide käsitlemiseks

Meie tooted on valmistatud silmas pidades väga täpseid kvaliteedistandardeid. Juhul kui olete saanud praaktoote, palume Teil toimetada see kas meie edasimüüja juurde või võtta ühendust esindusega. Samuti palume alles hoida ostutšekk ning vajadusel anda informatsiooni tootenumbri ja ostu sooritamise aja kohta.

LV GARANTIJA

Izstrādājumam ir garantija saskaņā ar ražotāja standartiem.

Instrukcija kvalitātes problēmu gadījumā

Mūsu produkcija tiek ražota pēc ļoti striktiem kvalitātes kritērijiem. Taču – gadījumā, ja produktam tiek konstatēta kvalitātes problēma – lūdzu, sazinieties ar pārdevēju. Lūdzu, esiet gatavi arī uzrādīt pirkuma čeku ar pirkuma datumu.

LT GARANTIJA

Gaminiams garantija suteikiama atsižvelgiant į konkrečios šalies kokybės reikalavimus.

Reklamacijos

Mūsų produkcija pagaminta vadovaujantis griežtais kokybės reikalavimais. Jei gaminys nekokybiškas – prašome jį grąžinti pardavėjui, pateikiant pirkimo čekį, gaminio numerį bei nurodant pirkimo datą.

ГАРАНТІЯ

Ця продукція підтримується гарантією у відповідності з правилами та законами, що діють у країні збуту.

Рекламації

Наша продукція відповідає сучасним стандартам та вимогам щодо якості. У випадку виникнення несправності, Ви можете звернутися в торгову організацію, де був придбаний цей виріб. Для оформлення рекламації необхідно додати супровідні документи щодо виробу та чек, що підтверджує найменування та дату покупки

RU ГАРАНТИЯ

Гарантийные условия устанавливаются в соответствии с законами и правилами, которые действуют в стране сбыта.

Рассмотрение рекламаций

Наша продукция соответствует современным стандартам и требованиям к качеству. В случае возникновения неисправности Вы можете обратиться в торговую организацию, где было приобретено данное изделие. При заявлении рекламации необходимо предъявить сопроводительные документы к данной продукции и чек, подтверждающий дату покупки.

GARANTII

Antud tootele kehtivad garantiitingimused tulenevad kohalikest õigusaktidest.

Juhised reklamatsioonide käsitlemiseks

Meie tooted on valmistatud silmas pidades väga täpseid kvaliteedistandardeid. Juhul kui olete saanud praaktoote, palume Teil toimetada see kas meie edasimüüja juurde või võtta ühendust esindusega. Samuti palume alles hoida ostutšekk ning vajadusel anda informatsiooni tootenumbri ja ostu sooritamise aja kohta.

GARANTIJA

Produktam ir garantija atbilstoši nozares noteikumiem konkrētajā valstī.

nstrukcijas sūdzību pieteikšanai

Mūsu produkti ir izgatavoti saskaņā ar ļoti stingriem kvalitātes prasībām. Tomēr, ja produkts ir bojāts, mēs lūdzam griezties produkta iegādes vietā. Mēs lūdzam arī sagatavot uzrādīšanai pirkuma čeku un informāciju par pirkuma datumu.

GARANTIJA

Gaminiams garantija suteikiama atsižvelgiant į konkrečios šalies kokybes reikalavimus.

Pretenzijos

Mūsų produkcija pagaminta vadovaujantis griežtais kokybes reikalavimais. Jei gaminys nekokybiškas – prašome jį grąžinti pardavėjui, pateikiant pirkimo čekį, bei nurodyti pirkimo datą



COLORIC

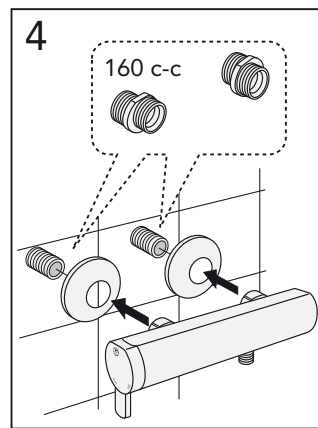
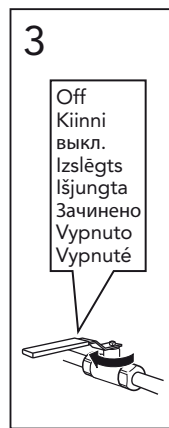
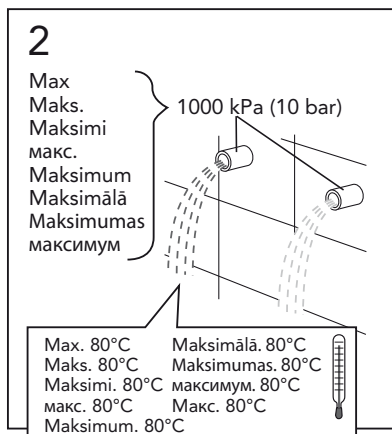
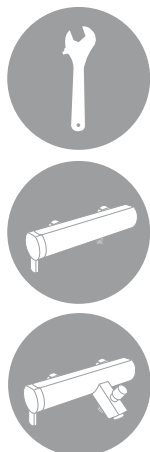
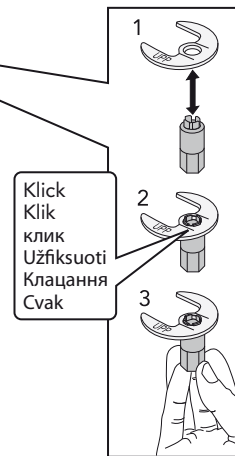
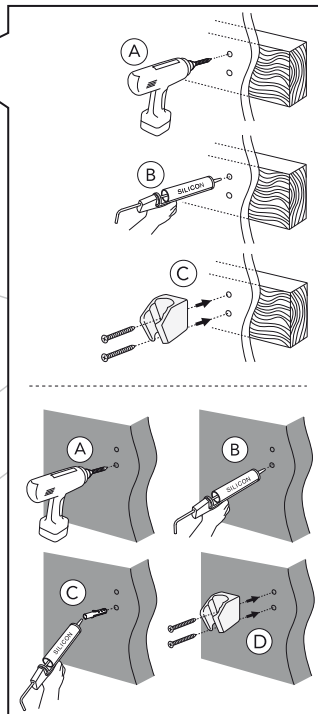
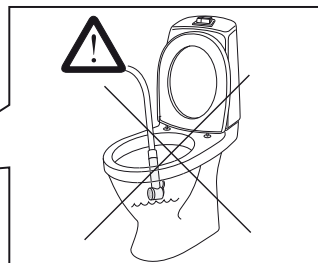
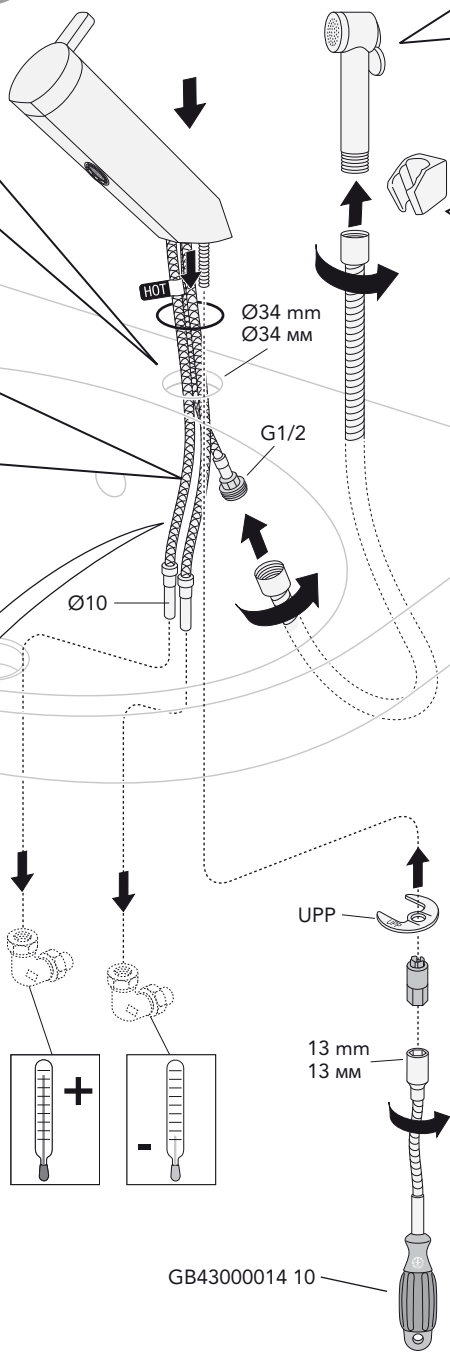
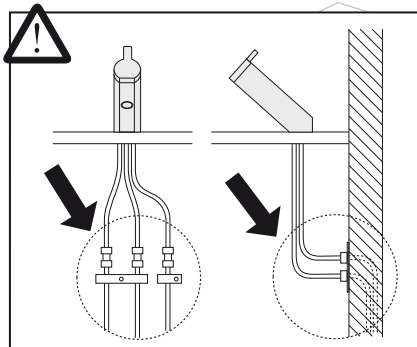
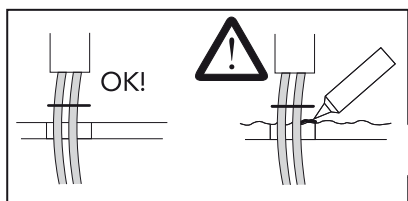



COLORIC

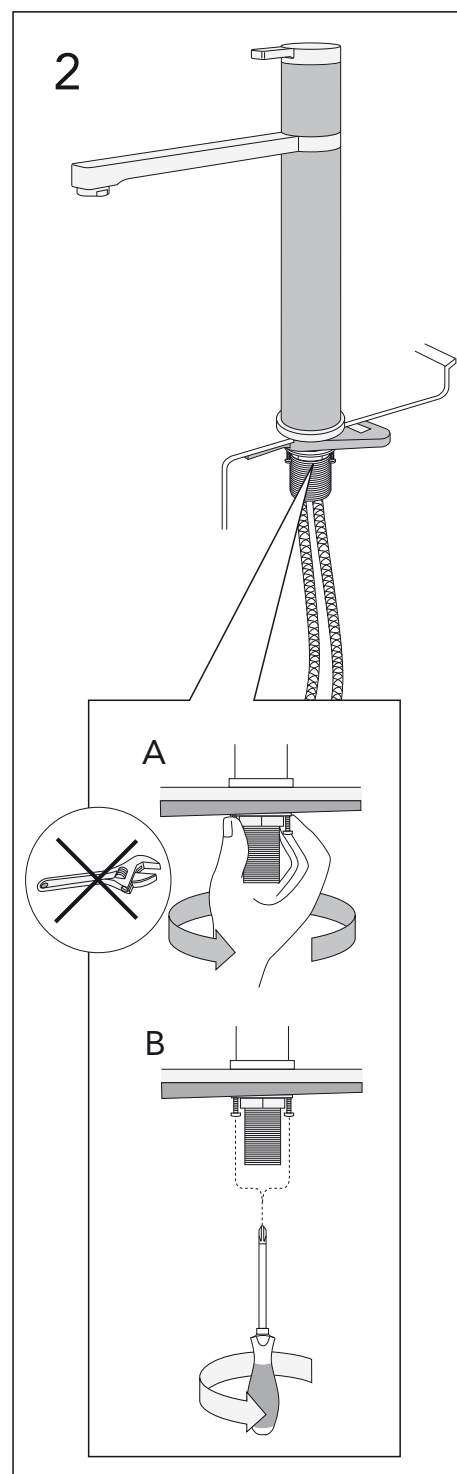
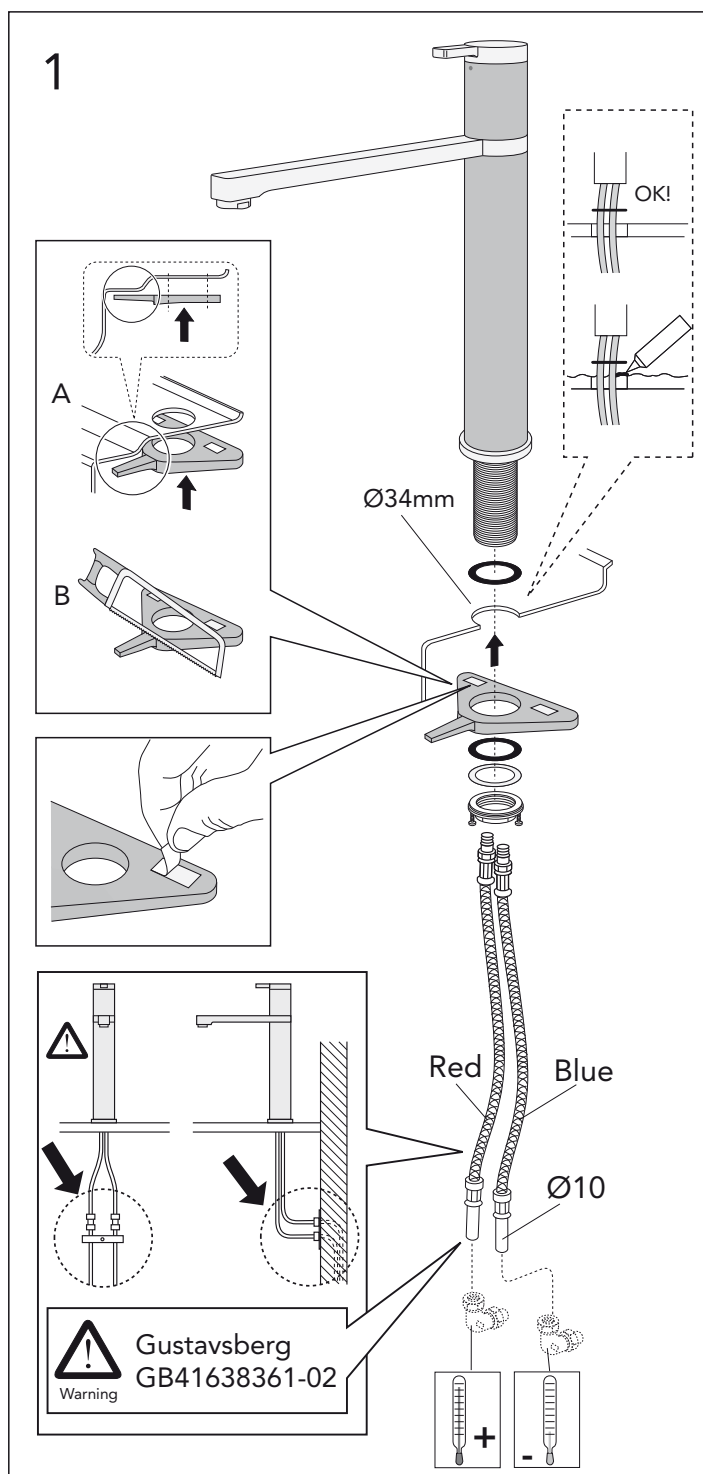

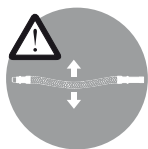

SOFTPEX

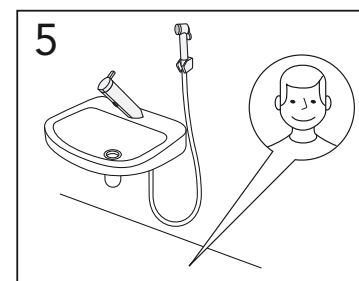
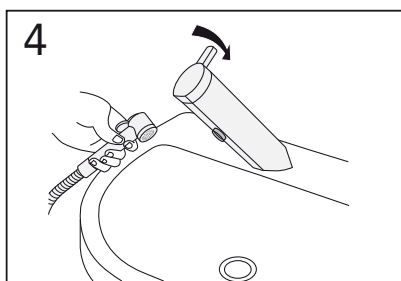
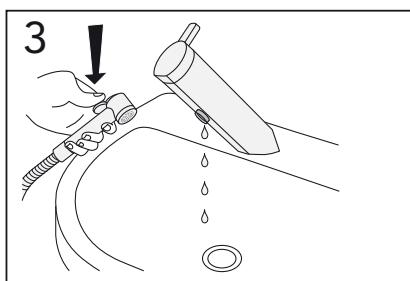
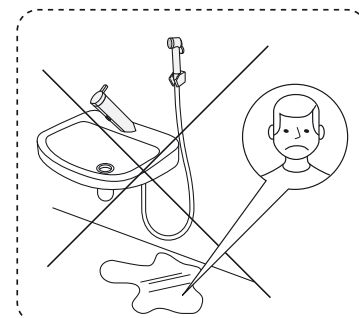
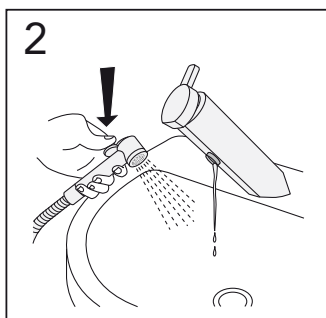
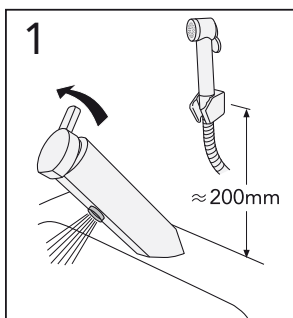
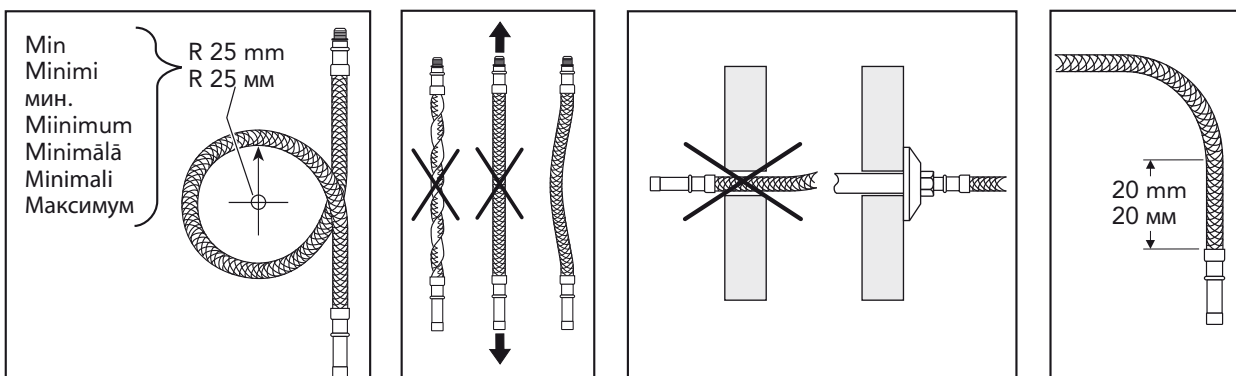



COLORIC

Pip
Spout
Tud
Tut
Juoksuputki
излив
Jooksutoru
Snipis
Snaras
Вилив
Ustí
Ústie

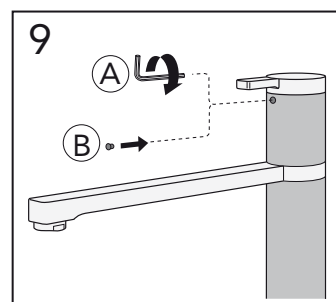
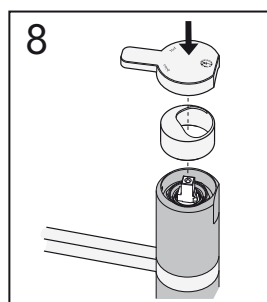
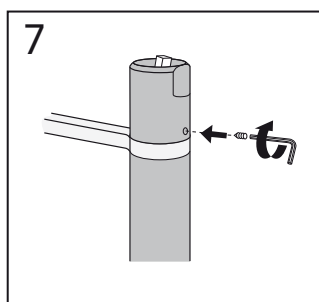
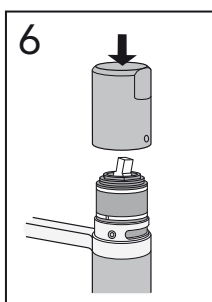
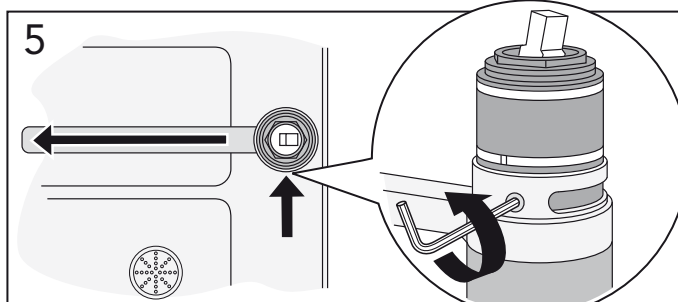
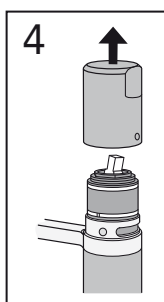
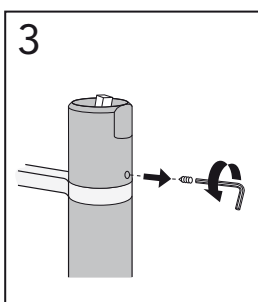
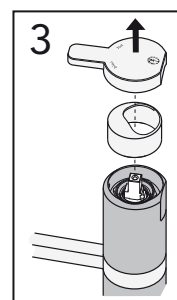
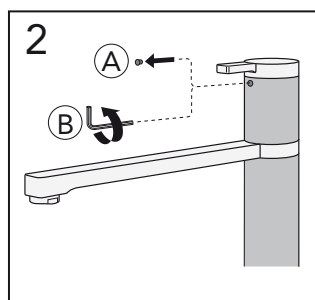
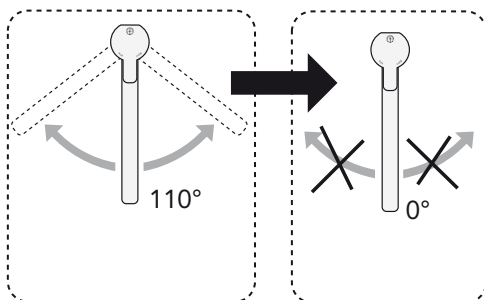



Justera komfortflöde
Adjustment water saving
Justere vandmængde
Justere komfortmengde
Säästövirtaaman säätö
Настройка функции водосбережения
Veehulga reguleerimine
Üdens taupišanas regulēšana
Vandens taupymo reguliuotojas
Налаштування збереження води
Nastavení úspory vody
Nastavenie úspory vody

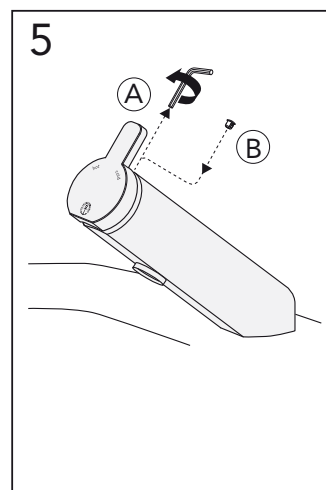
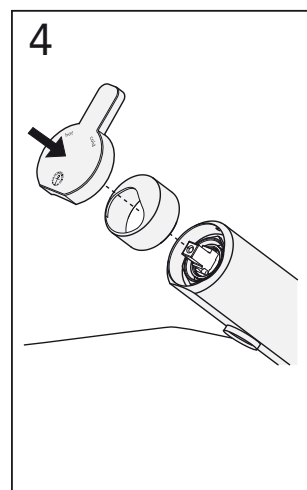
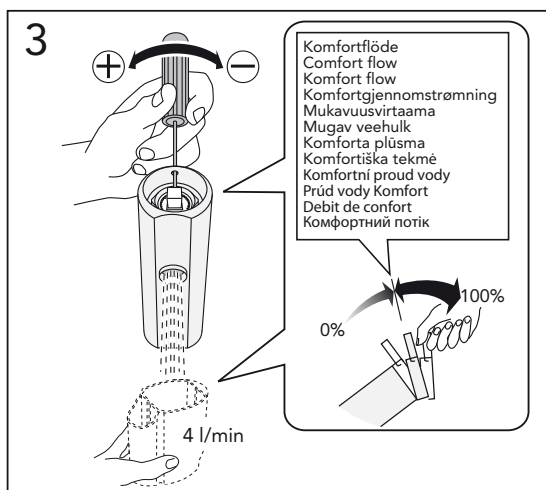
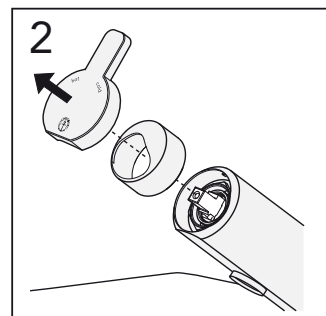
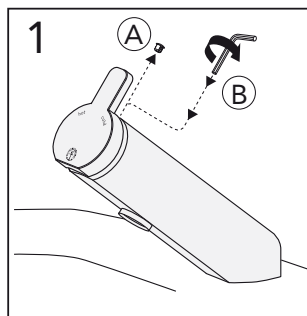

Justera komfortflöde
Adjustment water saving
Justere vandmængde
Justere komfortmengde
Säästövirtaaman säätö
Настройка функции водосбережения
Veehulga reguleerimine
Üdens taupišanas regulēšana
Vandens taupymo reguliuotojas
Налаштування збереження води
Nastavení úspory vody
Nastavenie úspory vody

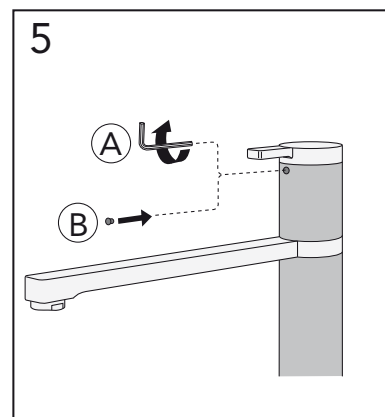
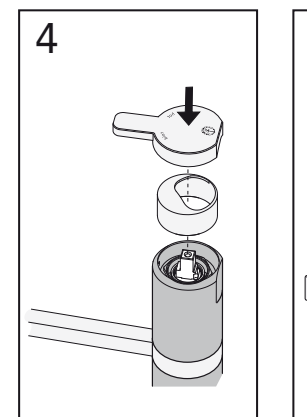
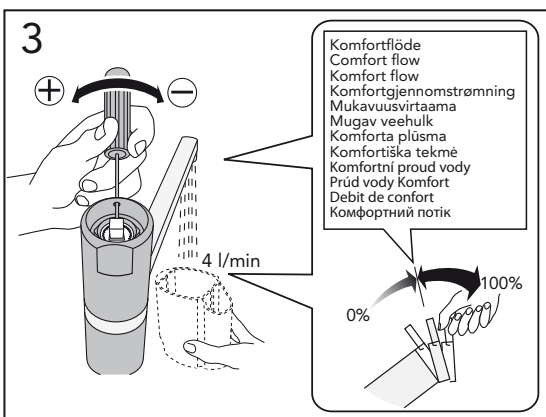
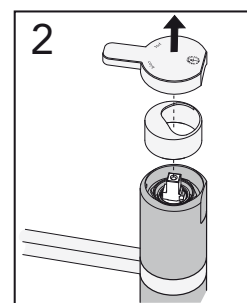
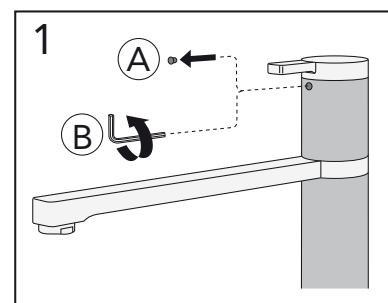



Skötsel
Maintenance
Beskyttelse
Vedlikehold
Hoito-ohje
Уход
Hooldus
Kopšanas informācija
Montavimas
Догляд
Péče o baterii
Starostlivosť o batériu

Don't use cleaning-agent unsuitable for aluminium
Warning

Klorin Chlorine (ClNaO)	Warning
	Warning
	Warning

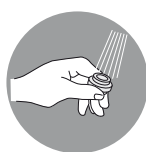
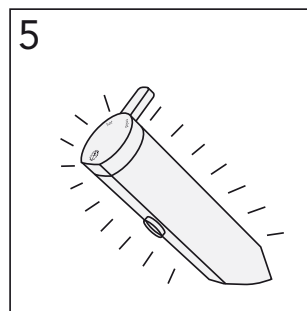
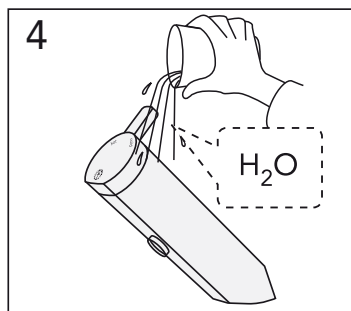
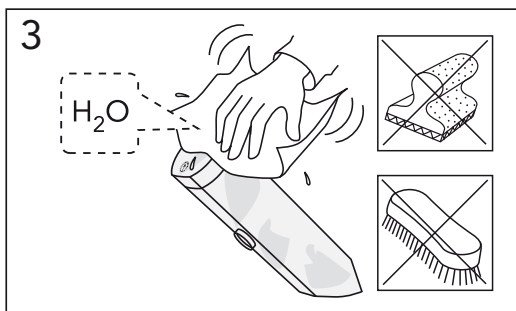
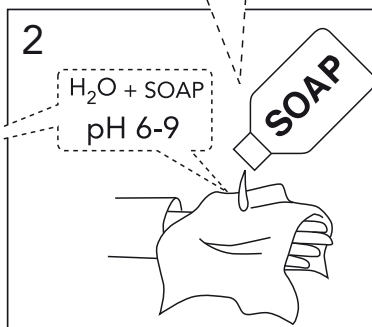
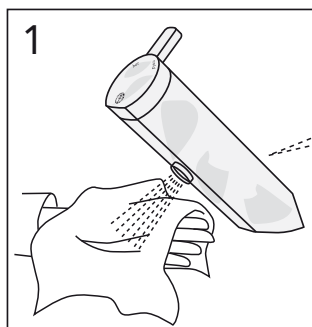

Rengöring
Clean
Rengjøring
Puhdistus
очистка

Puhastamine
Tīršana
Svarus
Очищення
Cisty

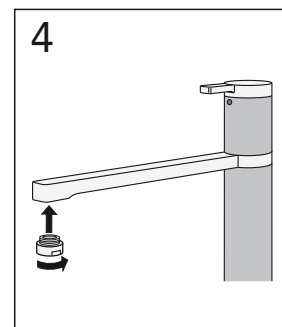
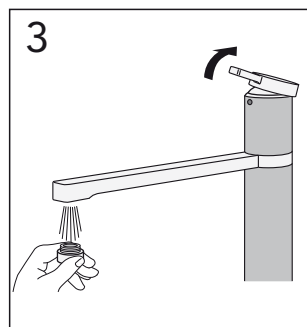
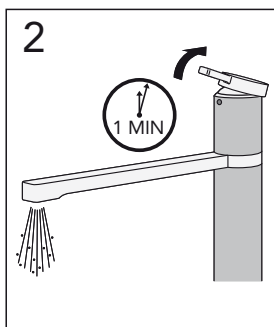
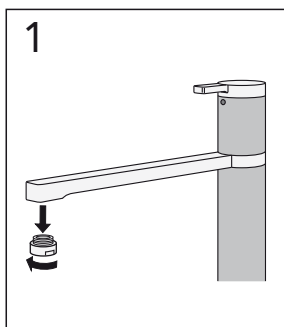
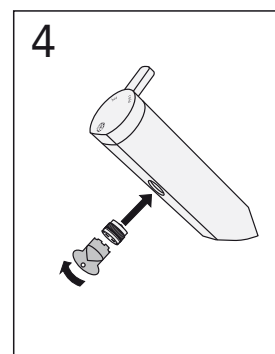
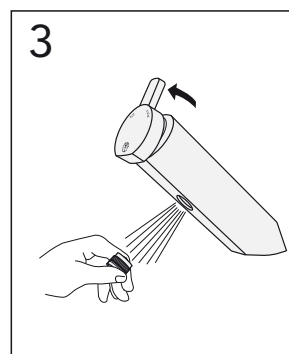
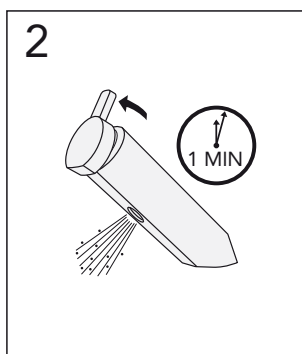
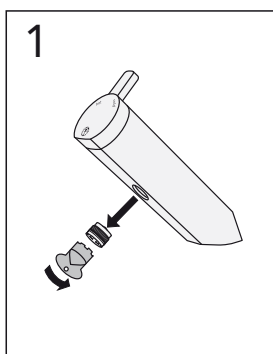



COLORIC

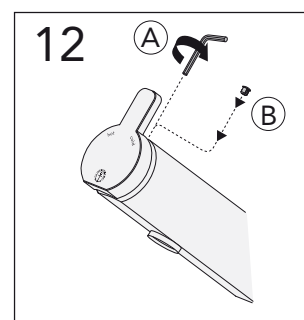
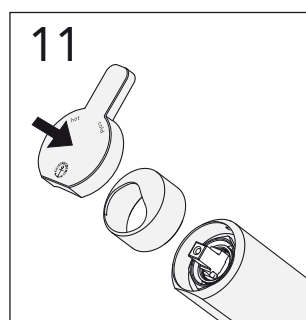
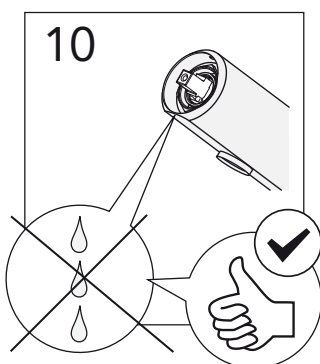
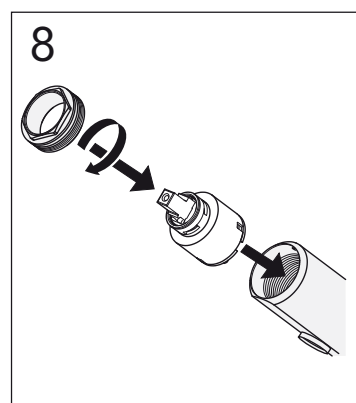
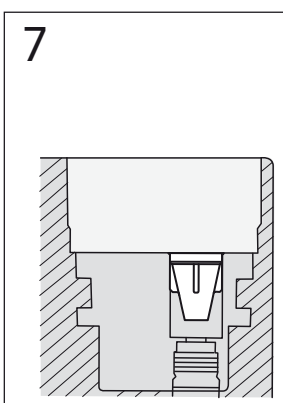
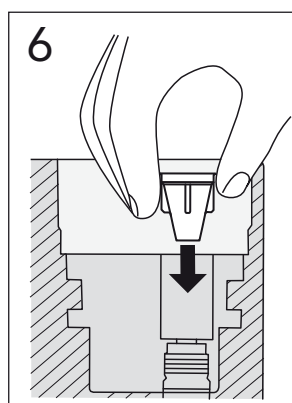
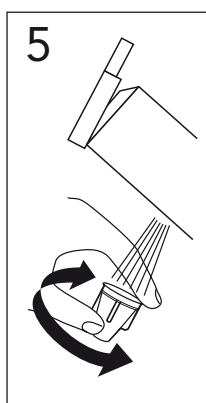
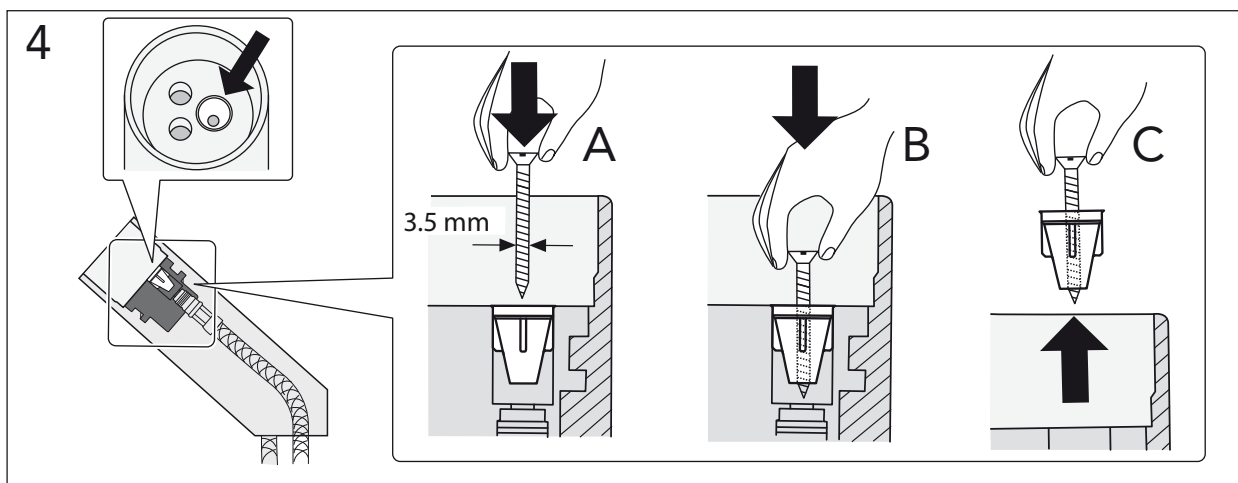
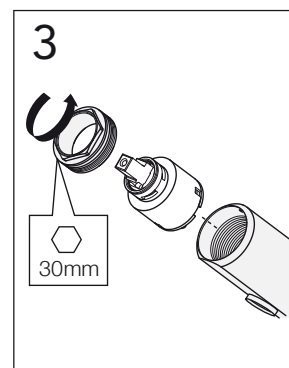
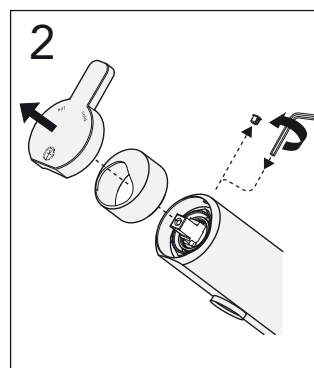
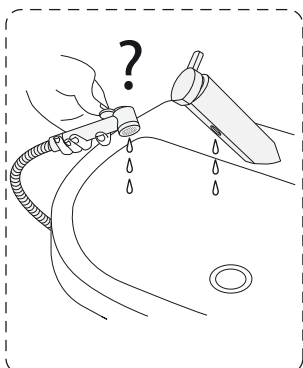



COLORIC

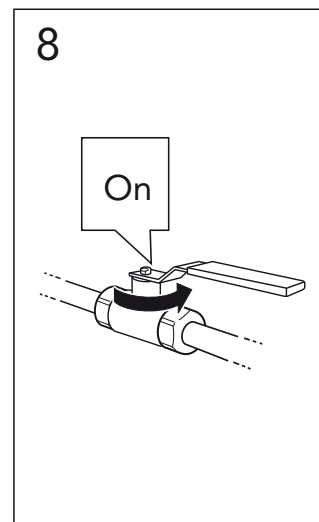
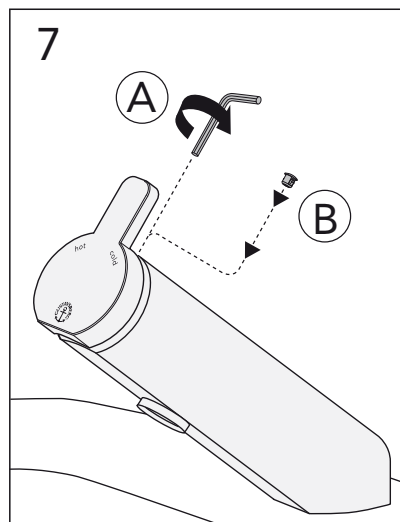
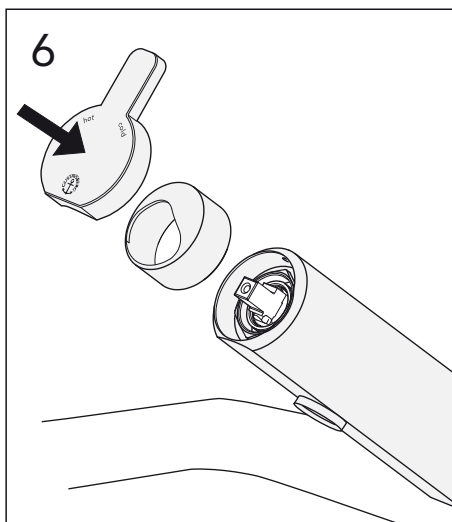
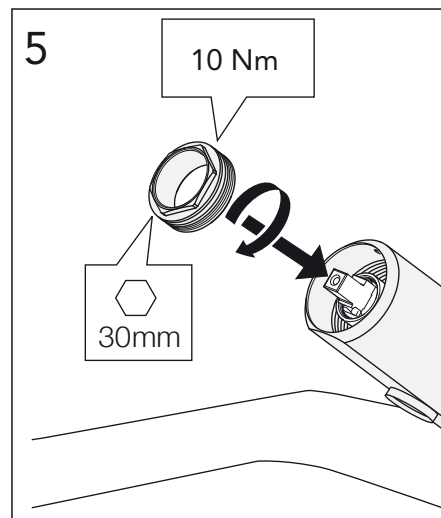
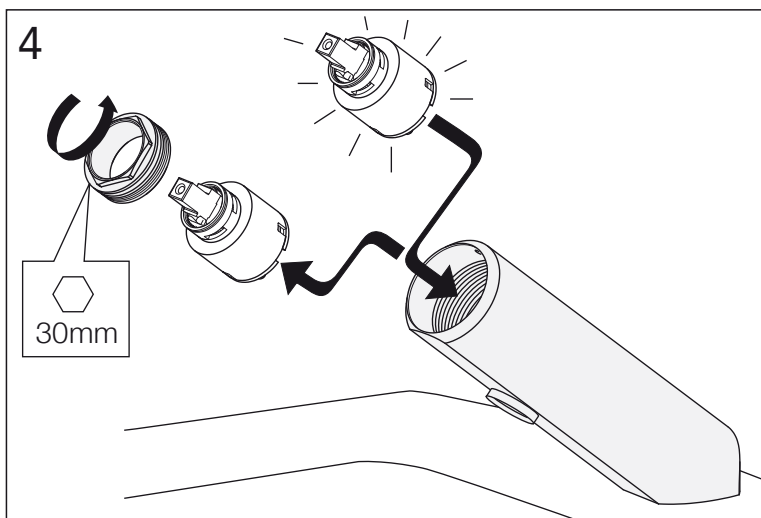
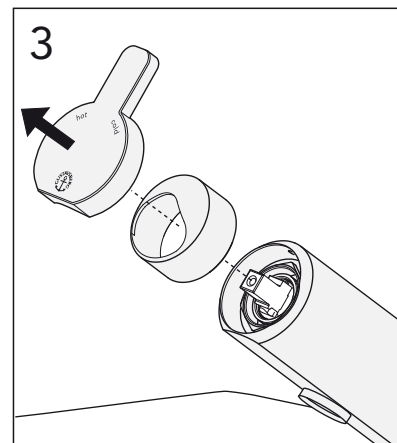
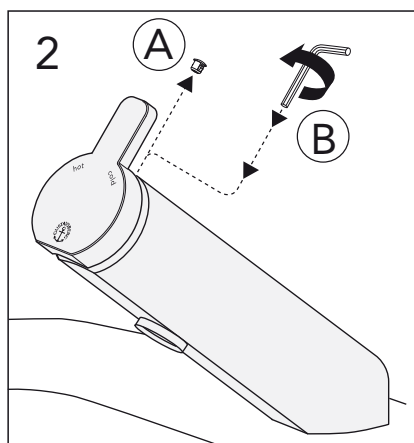
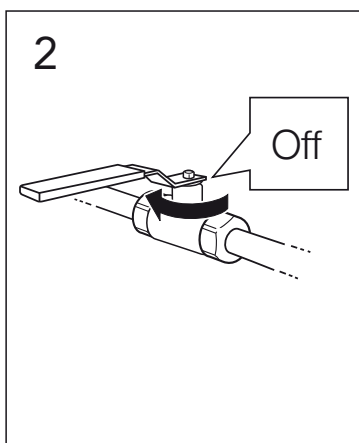





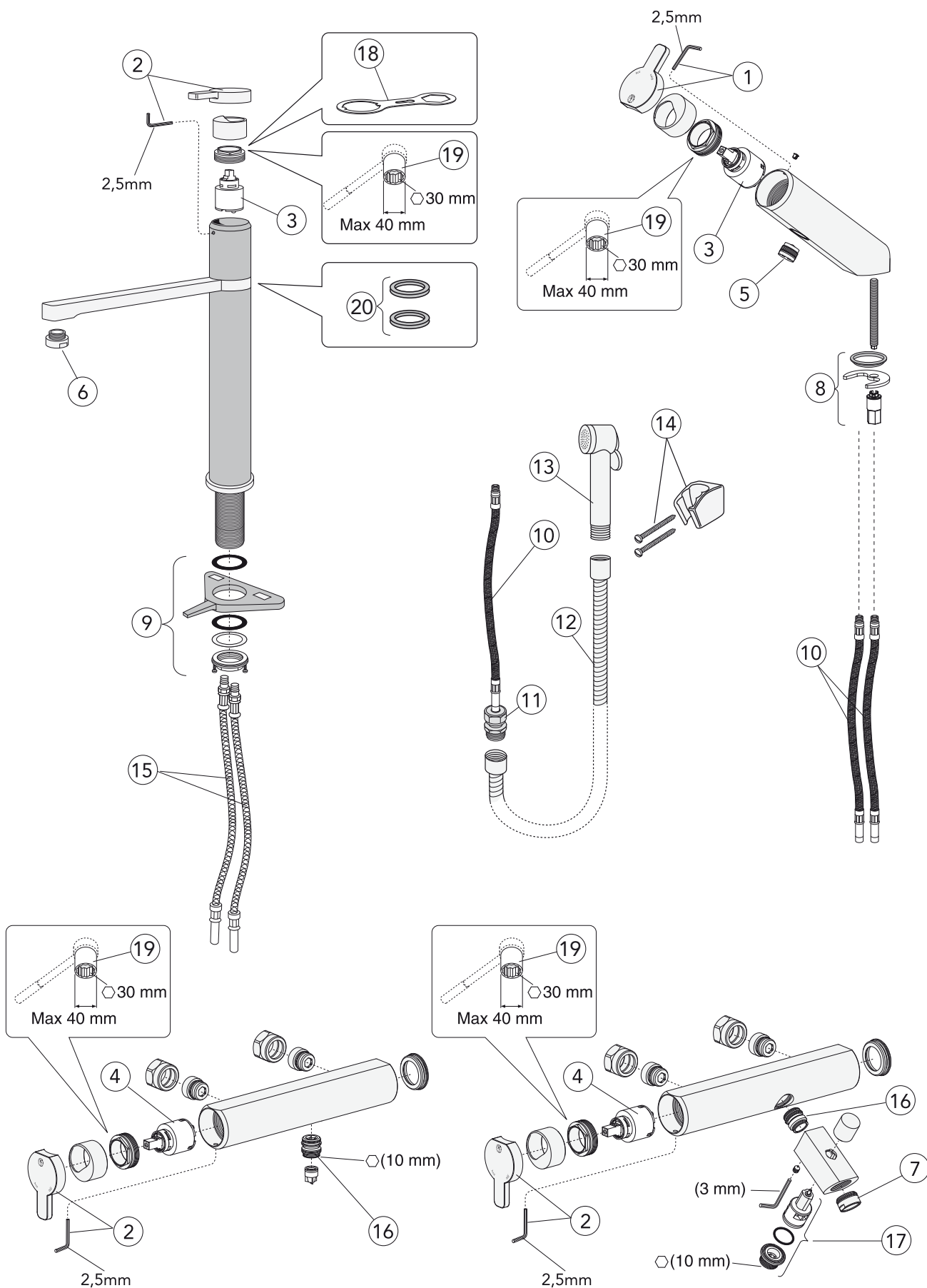







1 GB41637406	6 GB41630131 01	11 FG032033520	16 GB41637410
2 GB41637407	7 GB41637387 01	12 GB41636263 00	17 GB41637416
3 GB41637415	8 GB41637280 01	13 GB41633860 33	18 GB41637260
4 GB41637393	9 GB41638358 01	14 GB41637575	19 GB41638429 01
5 GB41637418	10 GB41637389 02	15 GB41638361 02	20 GB41633971 02





www.gustavsberg.com



-  Sweden / Sverige
-  English
-  Denmark / Danmark
-  Finland / Suomi
-  Norway / Norge
-  Estonia / Eesti
-  Russia / Россия
-  Latvia / Latvija
-  Lithuania / Lietuva
-  Ukraine / Україна

DRIFT & SKÖTSEL
 DRIFT OG VEDLIGEHODELSE
 DRIFT OG VEDLIKEHOLD
 ASENNUS-, KÄYTTÖ- JA HOITO-OHJEET
 ASSEMBLY AND MAINTENANCE
 PAIGALDAMINE & HOOLDAMINE
 MONTĀŽA UN KOPŠANA
 MONTAVIMAS IR PRIEŽIŪRA
 Сборка и техническая поддержка
 MONTÁŽ A ÚDRŽBA

LANGUAGE



SUPPORT



A MEMBER OF THE
 VILLEROY & BOCH GROUP

Sweden
 Villeroy & Boch Gustavsberg AB
 Box 400
 134 29 Gustavsberg
 Phone +46 8 570 391 00
 info@gustavsberg.com

Norway
 Villeroy & Boch Norge AS
 Lührtoppen 2
 Postboks 13
 1471 Lørenskog
 Tlf. + 47 67 97 82 50
 info.norway@gustavsberg.no

Estonia
 Villeroy & Boch Gustavsberg Oy Eesti Filiaal
 F. R. Faehlmanni 6
 10125 Tallinn
 Telefon + 372 646 0312
 E-mail: info@gustavsberg.ee

Lithuania
 Villeroy & Boch Gustavsberg Oy Filialas
 Maironio 25-23,
 Vilnius LT-01125
 Tel.: +370 5 2460811
 El.paštas: infolt@gustavsberg.com

Россия
 ООО "Виллерой и Бох"
 127287 Москва
 ул. 2я Хуторская, д.38А/9
 Тел.:+ 7 495 609 6560
 info.russia@gustavsberg.com

Denmark
 Villeroy & Boch Danmark A/S
 Hvidsværmervej 165 G
 2610 Rødovre
 Tlf + 45 36 70 80 55
 info@gustavsberg.dk

Suomi/Finland
 Villeroy & Boch Gustavsberg Oy
 Laippatie 14 b
 00880 Helsinki
 Puh +358 9 329 18 811
 myynti@gustavsberg.com

Latvia
 Villeroy&Boch Gustavsberg Oy parstavnieciba Latvija
 Krasta iela 68 A
 LV - 1019 Riga, Latvija
 Tālrunis: +371 6724 5511
 e-pasts: info.latvia@gustavsberg.com

Україна
 Представництво Villeroy & Boch Gustavsberg в Україні
 вул. Богдана Хмельницького 17/52а, оф. 401а,
 м. Київ, 01030
 тел: +38044 493 98 68
 info@gustavsberg.kiev.ua

Czech Republic / Slovakia
 Villeroy & Boch Czech s.r.o
 Türkova 2319/5b
 149 00 Praha 4 - Chodov
 Czech Republic
 Tel: +420 271 001 647
 info-cz@villeroy-boch.com